

– User Manual –

WW Models

Oxyfix® C-90 (1 to 99 PE)



Dear customer,

In purchasing this Waste Water Treatment Unit you have shown that you are truly concern for the protection of your environment and for the safeguarding of our precious water resources.

We thank you for the confidence that you have placed in us and in the **Oxyfix® C-90 unit** designed by Eloy Water.

These **Oxyfix® C-90** units are manufactured at our plant and workshops from specially formulated concretes offering a lighter, stronger and a more watertight unit than any other product available on the market.

We guarantee, provided the unit is installed in compliance with the instructions described in the Installation Manual and used in compliance with the Operation Manual, that your **Oxyfix® C-90** will comply with the standards in effect at the time of its installation.

For an optimal, economic and sustainable use of your **Oxyfix® C-90**, we strongly recommend that you read **this document** which includes the **Owner's Manual and the Installation Manual**, and to carefully follow the operating instructions.

For further information please do not hesitate to contact the distributor of your country. Their contact details can be found on our web site at www.eloywater.com.



Eloy Water s.a. , 13 rue des Spinettes – 4140 Sprimont (Belgique)

7

EN 12566-3+A1+A2 :2013

Packaged domestic wastewater treatment plant for treatment of domestic wastewater

- Product's reference code : **Oxyfix® C-90**

- Material : **Concrete**

Products :	Oxyfix C-90 4 EP	Oxyfix C-90 5 EP	Oxyfix C-90 6 EP	Oxyfix C-90 7 EP	Oxyfix C-90 9E EP	Oxyfix C-90 11 EP	Oxyfix C-90 14 EP	Oxyfix C-90 17 EP	Oxyfix C-90 20 EP	Oxyfix C-90 27 EP	Oxyfix C-9038 EP	
Effectiveness of treatment	COD : 90% DOB5 : 96% SS : 96% NH ₄ -N :96% Ptot : 30% Treatment efficiency ratios (at tested organic daily load BOD5 = 1,08 kg/d)	Performances equal to Oxyfix C-90 4 PE or 20 PE							COD : 91,5 % DOB5 : 6,3% SS : 95,4% NH ₄ -N :84,9% Ptot : 38,4% Treatment efficiency ratios (at tested organic daily load BOD5 = 1,15 kg/d)	Performances equal to Oxyfix C-90 4 PE or 20 PE		
Treatment capacity : (nominal designation)	0,24 kg/j	0,30 kg/j	0,36 kg/j	0,42 kg/j	0,54 kg/j	0,66 kg/j	0,84 kg/j	1,02 kg/j	1,2 kg/j	1,62 kg/j	2,28 kg/j	
- Nominal hydraulic daily flow (QN)												
- Nominal organic daily load (BOD5)	0,6 m ³ /j	0,75 m ³ /j	0,90 m ³ /j	1,05 m ³ /j	1,35 m ³ /j	1,65m ³ /j	2,1 m ³ /j	2,55 m ³ /j	3,00 m ³ /j	4,05 m ³ /j	5,7 m ³ /j	
Watertightness : (Water test)	In accordance with											
Crushing resistance : (pit test)	- Backfill 0,8 m - Wet ground conditions with water table level equal to the tank height											
Durability (concrete resistance) : C55/67	Reaction to fire : NPD					Release of dangerous substances : NPD						

Safety guidelines

We strongly recommend that any service or repair action be solely undertaken - other than for those actions that we refer to as "appropriate monitoring" in our maintenance contracts - by our Company's Field Service Technicians.

Risk Prevention

All personnel servicing the treatment plant shall wear appropriate PPE.

Safety reminders to keep in mind:

- Wearing **safety footwear** is compulsory for workers handling heavy parts to protect them against injury from heavy falling objects ;
- Wearing safety gloves is mandatory for workers in contact with sharp, stinging, irritating, burning or rough objects or material;
- Wearing **Safety Glasses** is mandatory for workers exposed to the risk of hazardous substances splashing, of particles projected by saws, of grinders or of harmful radiations produced during welding and cutting operations.
- Wearing **appropriate masks** is mandatory when the atmosphere contains dust or hazardous and noxious substances ;
- Wearing **personal hearing protection** is required when working near noisy machinery.

In terms of workplace health and safety, the major hazards associated with a waste water treatment unit are outlined below:

➤ Biological Risks

The wastewater and the sludge contain **bacteria and living pathogenic viruses**.

Direct contact of the hands (and any other part of the body) with such substances must be avoided as much as possible. Wearing **safety gloves** and **suitable clothing** is mandatory. It is strongly advised to refrain from drinking, eating, smoking, or touch one's face with his hands as long as a person is in contact with polluted water and until it has washed and disinfected its hands.

In case of contact with pathogenic substances, one should wash **and disinfect** the soiled parts of his body using specific cleaning products and avoid wearing the soiled clothing until they have been cleaned and disinfected.

It is also recommended to **wash and disinfect** the tools and objects that have been in contact with these pathogenic substances.

➤ Mechanical Hazards

It is recommended to use great care near **electromechanical devices**, some of which operate on an automatic cycle (where pumping stations are used).

Manholes, manhole covers, and gratings shall only be kept open long enough to complete the service or repair action. Once the service action is completed, the manhole covers shall be closed and locked by means of a quick opening and closing device.

Lock-out measures shall be taken to make it impossible for a machine to start-up accidentally whilst personnel is undertaking a service or repair action.

➤ Dangers related to gases

Some gases can cause discomfort or asphyxiations. It shall be forbidden for **a single person to climb down inside a unit containing** or that has contained any wastewater and to generally climb down inside a confined space.

Where applicable, the tank must be ventilated before any access is allowed. A **second person** must be present on site - just outside of the confined space - for the entire duration and whilst the service action is carried out to help the worker to come back up should he feel dizzy or unwell and to seek help. The second person shall not climb down inside the confined space under any circumstances.

➤ Risk of electric shock

Electrical service repair actions, including any alterations made to the said facilities shall be only be carried out by **skilled personnel**.

Table of contents

I. User Manual	1
1. Eloy Water	1
1.1. Foreword	1
1.2. Background	1
1.2.1. Preamble	1
1.2.2. User Manual	2
1.3. Design guidelines	2
2. General Description of your Oxyfix® C-90 unit	3
2.1. Operating Principles	3
2.2. The various components of your Oxyfix® C-90 Unit	4
2.3. Quality Components	7
2.3.1. Concrete tanks	7
2.3.1.1. General Remarks	7
2.3.1.2. Reinforcement	7
2.3.2. Manholes and access	7
2.3.3. Air distribution and air supply piping	7
2.3.4. Blower	7
2.3.4.1. Oxyfix® C-90 (1-4 to 21-27 EP)	7
2.3.4.2. Oxyfix® C-90 (28-38 to 76-99 EP)	8
2.3.5. Sludge recirculation device	8
2.3.5.1. Oxyfix® C-90 (1-4 to 21-27 EP)	8
2.3.5.2. Oxyfix® C-90 (28-38 to 76-99 EP)	8
2.3.6. Pipes	8
2.3.7. Other components	8
2.4. Performances	9
3. Use and maintenance of the Oxyfix® C-90 Unit	9
3.1. Instructions for Use	9
3.2. Servicing	9
3.2.1. Regular servicing of the unit is a highly recommended means of monitoring the unit	9
3.2.1. A Service agreement will guarantee that your unit is properly maintained	10
3.3. Emptying the sludge	11
3.4. Sampling the treated water	12
3.5. Procedure in case of malfunction	13
3.6. Replacement of wear parts	13
3.6.1. Air filter of the blower	13

3.6.2.	Blower diaphragms (only for the Oxyfix® C-90 4 to 27 PE units)....	13
3.6.3.	Fine bubble air diffusers	14
3.6.4.	Media (Oxybee).....	14
4.	A few tips.....	15
5.	Traceability	15
6.	Warranties.....	16
7.	Service Guide Appendices	17
	Appendix 1 Example of a Service Check Sheet (with service agreement)	17
	Appendix 2 Example of a Service Check Sheet (without a service agreement) .	18

II. Installation manual 19

1.	Implementation and installation	20
1.1.	Location	20
1.2.	Topographical and Discharge Conditions	20
1.3.	Transport.....	24
1.4.	Handling the tank	25
1.5.	Excavation and lowering the unit in the ground	26
1.6.	Backfilling	28
1.7.	Hydraulic Connection	29
1.8.	Vent pipe.....	29
1.9.	Finishing.....	31
1.10.	Installation under high water table conditions.	31
1.11.	Sludge recirculation connection.....	33
1.11.1.	Oxyfix® C-90 1-4 to 6 PE	33
1.11.2.	Oxyfix® C-90 7 to 21-27 PE	33
1.11.3.	Oxyfix® C-90 28-38 to 76-99 PE	34
1.12.	Blower connection to Oxyfix C-90®.....	35
1.12.1.	Diaphragm blowers (Oxyfix® C-90 1-4 to 21-27 PE)	36
1.12.2.	Side channel blowers (Oxyfix C-90® 38 to 99 PE)	36
1.13.	Electrical connection	37
1.13.1.	Connecting diaphragm blower.....	37
1.13.2.	Connecting side chanel blower and its temperature sensor.....	38
1.13.3.	Connecting electrical to panel (only applies to Oxyfix® C-90 28-38 to 76-99 PE)	39
1.14.	Instructions for control panel using (only applies to Oxyfix® C-90 28-38 to 76-99PE)	39
1.14.1.	Motors control :	40
1.14.2.	Load rate switch	40
1.14.3.	Instructions for using the Siemens LOGO PLC.....	40
1.14.4.	List of faults	42
1.14.5.	Magnetic circuit breaker rarming procedure :	43

2. Commissioning.....	44
3. Inspecting the Oxyfix® C-90.....	44
4. FAQs.....	44

I. User Manual

Submerged Aerobic Fixed Film
Biomass Growth

Oxyfix® C-90 Range (1 to 99 PE)



1. Eloy Water

1.1. Foreword

Eloy Water is a Belgium based company that has a high level of expertise in the design, manufacture, marketing and maintenance of waste water and of surface run-off water treatment systems.

It is part of the Eloy Water Group of Companies established in 1965 which specialises in environmental protection and management activities.

The Eloy Group of Companies today employs more than 300 people for an annual turnover exceeding 50 million euros.

Eloy Water holds in stock a complete range of standard efficient and reliable products which are readily available to its network of approved distributors and installers including: single dwelling and semi-collective waste water treatment systems, rainwater harvesting tanks, oil/water separators, grease traps and pumping stations.

The different treatment systems developed by the company are integrated in high-performance steel fibre reinforced concrete tanks, in fibreglass reinforced polyester tanks or in specially designed polyethylene tanks.

For more information on Eloy Water and its products, please visit our web page at: www.elaywater.com



Fig-1 : Eloy group's manufacturing site

1.2. Background

1.2.1. Preamble

The sewage from our homes requires to be discharged and returned to the natural environment whilst safeguarding public health and the environment.

It is therefore appropriate to treat the contaminants carried by the wastewater we produce (mainly organic matter, nitrogen and phosphorus) in order to limit their impacts on our aquatic environments.

A stand-alone mode of sewerage treatment provides the best technical and economical solution in rural areas. This type of sewerage treatment is suitable for individual dwellings and for small

communities that are not connected to the public sewage system. The stand-alone mode of sewerage treatment is recognized as a real option to using the public sewage system and at least as effective, with less environmental impact in rural areas.

1.2.2. User Manual

Long regarded as an interim solution until a public sewage system can be made available (main sewer network), the stand-alone sewerage system nevertheless provides a technically and economically sustainable solution. Provided of course that the unit is properly designed, installed and regularly serviced. This is precisely the purpose of this User Manual.

This user manual is to be used for the Eloy "Oxyfix® C-90" range of products to treat domestic wastewater from 1 to 99 equivalent - people (EP).

1.3. Design guidelines

The effective capacity of the single dwelling waste water treatment system is based on the number of equivalent people (EP) living in a single house or in the number of dwellings that the system has to service.

The units have been designed to treat the domestic wastewater based on the following loads:

Daily Organic Load	60	gO ₂ /EP
Daily Hydraulic Load	150	l/EP

For example, the Oxyfix® C-90 5 EP unit can treat the waste water of a dwelling having up to 5 equivalent people, i.e. up to 750 litres/day and an organic load of 0.3 kgO₂ /day.

As a matter of information, the average consumption of water per day and per person varies rather between 80 and 110 litres, hence the capacity of your Oxyfix® C-90 unit to accept sudden load variations.

 Eloy Water will need to be informed in advance of any changes made to your private dwelling in terms of accommodations and facilities (adding new rooms or washing facilities, increase in the number of people using the premises, etc.). Otherwise, your Oxyfix could suffer from serious malfunctions and lose its performance warranty.

2. General Description of your Oxyfix® C-90 unit

The Oxyfix® unit is a biological sewage treatment plant, which uses a submerged aerated fixed-film (SAFF) technology. The water is treated by a population of bacteria fixed to an unalterable plastic media, or Oxybee ®. The Oxybee's high surface area (200m²/m³) provides for optimum biomass growth without any risk of clogging (90% of voids).

THE Oxyfix® C-90 incorporates several technically innovative features which makes it all the more efficient, economic and sustainable. These features include:

- ✓ Rectangular Tanks: providing for excellent stability and requiring a smaller amount of backfill compared to round tanks.
- ✓ The primary decanter holds a large volume
- ✓ Limited footprint
- ✓ Minimum inflow and outflow level difference
- ✓ Easy access to all components
- ✓ Gravity Flow
- ✓ Treatment efficiency exceeds 90%



Fig-2: **Typical Oxyfix® C-90 concrete tank unit**

2.1. Operating Principles

Your Oxyfix® C-90 operates using a technology known as Submerged Aerated Fixed Film (SAFF) technology which is ideally suited to small and medium sized treatment facilities and where polluting loads vary considerably.

The Oxyfix® C-90 units are supplied as one or more concrete tanks, which always features three distinctive treatment compartments.

Compartment 1 (Primary decanter): The waste waters are collected in the primary decanter. The suspended matter settles down in the lower part of this compartment where it is partly "broken down" by anaerobic bacteria. In effect, this is where the anaerobic digestion and liquefaction phases occur. The primary decanter also acts as a grease trap.

In time, a crust formed from the accumulated cooking fats and cellulose will probably appear at the surface of the primary decanter.

The Oxyfix® C-90 is also fitted with a vented Tee pipe which is submerged under this crust so that the waste water can flow unimpeded through to the next stage of the process.

This Tee pipe also reduces turbulence and calms the water inside the decanter, which provides two additional advantages:

- the anaerobic bacteria can continue to thrive without being disrupted by a sudden and turbulent inflow of sewage water;
- the calm water environment also provides for better sedimentation of the solids.

Compartment 2 (biological reactor) : The "pre-treated" water then flows through a pipe down to the bottom of the biological reactor, where the partly treated organic matter will be broken down by aerobic bacteria.

The oxygen required for bacterial growth is supplied by a blower.

This air blower is connected to an air distribution piping system. This air distribution system is fitted at the bottom of the biological reactor with "fine bubble" air diffusers.

The distinctive feature of this system lies in the fact that the micro-organisms in the biological reactor proliferate and attach themselves to a unique type of submerged media: the Oxybee®.

Compartment 3 (clarifier): On leaving the biological reactor the treated water then flows through to the clarifier. Any entrained solids settle at the bottom of the clarifier.

The clear water then flows out of the clarifier through an outlet fitted on the upper part of the clarifier where and as an extra precaution, a device is used to catch any floating matter. This device has been specially designed to be easily accessible and to easily take representative samples of the treated water.

The clarifier is fitted with a settling cone which concentrates the sludge at the bottom of the compartment from which the settled sludge can be pumped out through the sludge recycling system (airlift or pump).

The airlift or the recirculation pump allows for recycling the treated water and the sludge from the clarifier back to the primary decanter. This recirculation avoids uncontrolled denitrification which would cause the sludge to float on the surface of the treated water. Recirculation also promotes a partial denitrification of nitrates in the first compartment and a good nitrification of the residual Kjeldahl nitrogen by forcing the solution through the biological reactor for a second time.

2.2. The various components of your Oxyfix® C-90 Unit

Your Oxyfix® C-90 unit is made up of a single or of several concrete tanks ranging from 4,500 to 20,000 litres laid out as follow:

Single tank unit (Oxyfix® C-90 (1-4 to 6 EP))

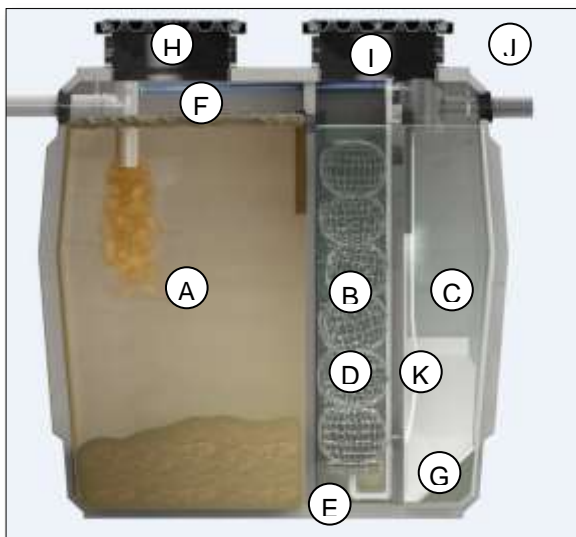

- A : Primary Decanter
- B : Biological reactor
- C : Clarifier
- D : Media
- E : Air Diffusers
- F : Sludge Recirculation
- G : Settling Cone
- H : Primary decanter manhole opening
- I : Biological reactor manhole opening
- J : Monitoring device
- K : Airlift

Fig-3: Pictorial diagram of the Oxyfix® C-90 Single Tank Unit

Two tank unit (Oxyfix® C-90 (7 to 21-27 EP))

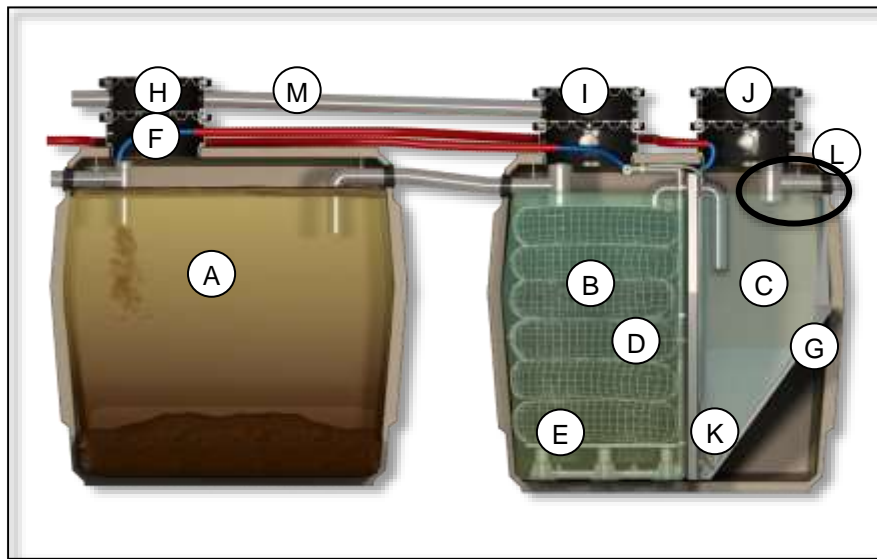

Fig-4: Pictorial diagram of the Oxyfix® C-90 Two Tank Unit

Details :

- | | |
|--------------------------|--------------------------------------|
| A : Primary decanter | H : Primary decanter manhole opening |
| B : Biological reactor | I : Biological reactor manhole |
| C : Clarifier | J : Clarifier manhole opening |
| D : Media | K : Airlift/Recirculating pump |
| E : Air diffusers | L : Moniroting device |
| F : Sludge recirculation | M : Vent pipe |
| G : Settling cone | |

Three tank unit (Oxyfix® C-90 (28-38 to 76-99 EP))

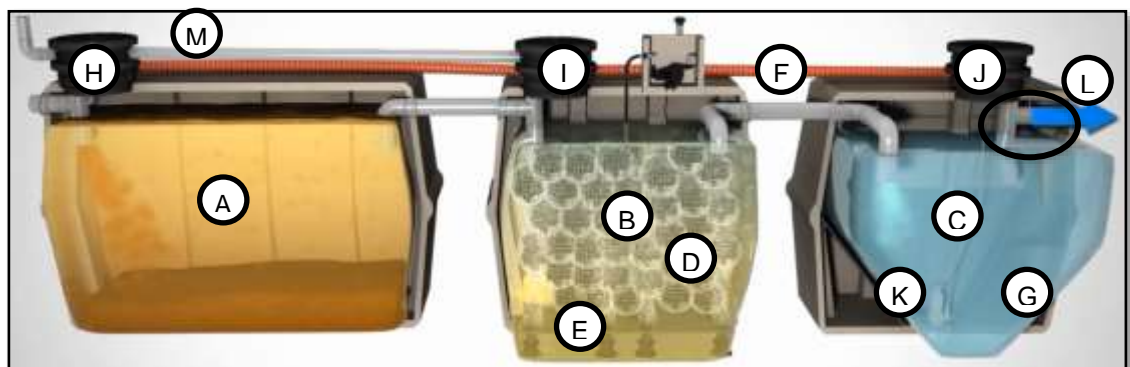

Fig-5: Pictorial diagram of the Oxyfix® C-90 Three Tank Unit

Details:

- | | |
|--------------------------|--|
| A : Primary Decanter | H : Primary decanter manhole opening |
| B : Biological reactor | I : Biological reactor manhole opening |
| C : Clarifier | J : Clarifier manhole opening |
| D : Media | K : Recirculating pump |
| E : Air Diffusers | L : Monitoring device |
| F : Sludge Recirculation | M : Vent pipe |
| G : Settling Cone | |

2.3. Quality Components

Eloy Water systematically selects quality materials that have a minimum risk of deterioration and that can ensure the sustainable and efficient operation of your Oxyfix® C-90.

2.3.1. Concrete tanks

2.3.1.1. General Remarks

The tank is precast using a **self-compacting concrete**. This high-density concrete provides a denser and a more impermeable finished product and also provides a high-resistance to sulphates that are present in the wastewater.

2.3.1.2. Reinforcement

The concrete is reinforced with a specially designed **metal fibre** which gives the tank its outstanding strength.

2.3.2. Manholes and access

The Oxyfix® C-90 units are fitted with 600 mm manholes providing easy access to all of the components inside the Oxyfix® C-90.

Suitable concrete or polyethylene cover risers are also available to complete the installation (option).

The risers are closed using concrete, cast iron or polyethylene covers which are manufactured for standard pedestrian traffic. The covers can be adapted for specific loads and according to requirements.

2.3.3. Air distribution and air supply piping

The air distribution system, the piping and the accessories are made from PVC pressure pipe according to standard EN 1452.

The pipes are fitted to the walls of the biological reactor using plastic and corrosion proof pipe rings.

The Oxyfix® C-90 is fitted with "fine bubble" air diffusers" which uses micro-perforated membrane to ensure proper air diffusion. Threaded end pieces (3/4 inch) are used to connect the diffusers to the air distribution system and to make it easier during assembly and dismantling.

2.3.4. Blower

2.3.4.1. Oxyfix® C-90 (1-4 to 21-27 EP)

The blower must be installed in a properly ventilated, temperate, clean, dry, sheltered area and protected from splashing water. Wherever possible, please try to place the blower in a frequently visited area (garage, cellar, etc.) remembering that the blower is fitted with a red indicator light that lights up in the event of a malfunction.

Suitable concrete or polyethylene boxes are also available to complete the installation (option).

2.3.4.2. Oxyfix® C-90 (28-38 to 76-99 EP)

The blower is installed in a utility chamber. This unit chamber must be free of moisture, ventilated and easily accessible.

The installation is completed with a polystyrene thermoplastic cabinet, fitted with two thermal magnetic circuit breakers, fuses (protection and timers), with two indicator lights (led), and a PLC complete with a LCD screen. The **green** indicator light means that the unit is working properly. The **red** indicator light indicates that there is an electrical fault.

2.3.5. Sludge recirculation device

2.3.5.1. Oxyfix® C-90 (1-4 to 21-27 EP)

The recirculation of the sludge from the clarifier to the primary decanter is carried out using an airlift, which is powered by the same blower as that which supplies the air distribution system. The airlift operates continuously and is regulated by the internal diameter of a quick pneumatic connection ensuring that a constant and proper volume of air is used both to power the airlift and to supply enough air to the diffusers.

The airlift is made using PVC pressure pipe which complies with Standard EN 1452 and is extended by a length of ribbed spiral reinforced hose which completes recirculation to the primary decanter. Air is supplied through a hose connected to the quick release coupling.

The airlift is fitted to the walls using plastic and corrosion proof pipe rings.

2.3.5.2. Oxyfix® C-90 (28-38 to 76-99 EP)

The sludge is recirculated by a recirculating pump which operates sequentially. The sludge from the clarifier is pumped back to the primary decanter.

2.3.6. Pipes

The pipe work is made from BENOR-Type PVC in compliance with standard EN 1401-1. The inlet and outlet connecting sleeves are delivered complete with SBR rubber seals.

2.3.7. Other components

All other components are insensitive to corrosion (synthetic or stainless steel type 1.4404 or 1.4521).

2.4. Performances

Eloy Water guarantees that, provided that the installation is carried out according to the User Manual and that the unit is used in compliance with the instructions given in the User Manual, the Oxyfix® C-90 complies with the standards in effect at the time of the installation of the unit and this immediately upon achieving its designed capacity, which normally shall take 3 to 4 weeks.

Your Oxyfix® C-90 is designed to treat domestic waste waters for equivalent populations (EP), ranging from 1-4, 5, 6, 7, 8-9, 10-12, 13-14, 15-17, 18-20, 21-27, 28-38, 39-58, 59-75, 76-99 EP, as per the following table:

Oxyfix® 1-4PE	DOB5	0,24	kgO2/day	Oxyfix® 5PE	DOB5	0,30	kgO2/day
	COD	0,54	kgO2/day		COD	0,675	kgO2/day
	SS	0,36	kg/day		SS	0,45	kg/day
	Fd	0,60	m ³ /day		Fd	0,75	m ³ /day
Oxyfix® 6PE	DOB5	0,36	kgO2/day	Oxyfix® 7PE	DOB5	0,42	kgO2/day
	COD	0,81	kgO2/day		COD	0,95	kgO2/day
	SS	0,54	kg/day		SS	0,63	kg/day
	Fd	0,90	m ³ /day		Fd	1,05	m ³ /day
Oxyfix® 8-9PE	DOB5	0,54	kgO2/day	Oxyfix® 10-12PE	DOB5	0,66	kgO2/day
	COD	1,215	kgO2/day		COD	1,485	kgO2/day
	SS	0,81	kg/day		SS	9,90	kg/day
	Fd	1,35	m ³ /day		Fd	1,65	m ³ /day
Oxyfix® 13-14PE	DOB5	0,84	kgO2/day	Oxyfix® 15-17PE	DOB5	1,02	kgO2/day
	COD	1,89	kgO2/day		COD	2,295	kgO2/day
	SS	1,26	kg/day		SS	1,53	kg/day
	Fd	2,1	m ³ /day		Fd	2,55	m ³ /day
Oxyfix® 18-20PE	DOB5	1,20	kgO2/day	Oxyfix® 21-27PE	DOB5	1,62	kgO2/day
	COD	2,70	kgO2/day		COD	3,64	kgO2/day
	SS	1,80	kg/day		SS	2,43	kg/day
	Fd	3,00	m ³ /day		Fd	4,05	m ³ /day
Oxyfix® 28-38PE	DOB5	2,208	kgO2/day	Oxyfix® 39-58PE	DOB5	3,48	kgO2/day
	COD	5,13	kgO2/day		COD	7,83	kgO2/day
	SS	3,42	kg/day		SS	5,22	kg/day
	Fd	5,7	m ³ /day		Fd	8,7	m ³ /day
Oxyfix® 59-75	DOB5	4,5	kgO2/day	Oxyfix® 76-99	DOB5	5,94	kgO2/day
	COD	10,125	kgO2/day		COD	13,365	kgO2/day
	SS	6,75	kg/day		SS	8,91	kg/day
	Fd	11,25	m ³ /day		Fd	14,85	m ³ /day

The level of treatment required corresponds to the following values:

Parameters	Maximum Concentrations after treatment*
COD	125 mg/l
BOD ₅	25 mg/l
SS	30 mg/l

* Measured on a daily average sample

Assumptions:

- For an effluent temperature of ≥ 12 °C and a pH of 6.5 to 9.5.
- Subject to the rated hydraulic and polluting loads

3. Use and maintenance of the Oxyfix® C-90 Unit

3.1. Instructions for Use

Please follow these instructions so that your Oxyfix® C-90 gives you full satisfaction and so that you do not void your warranty.

1. The treatment process used by the Oxyfix® C-90 resorts to living micro-organisms. Therefore the following substances will kill the working micro-organisms in the unit and should not be discharged :

- | | |
|---------------------------------------|--------------------------------------|
| - paints, varnishes, thinners ; | - wax and resins |
| - chemicals and drugs ; | - packaging (cardboard - plastic) ; |
| - fats and oils | - acids; |
| - bleach | - toilet chemicals ; |
| - non-biodegradable tissues ; | - water at temperatures greater than |
| - tampons, sanitary towels, nappies ; | 75°C ; |

Household cleaning products may be used within the limits of the manufacturer's recommendation. It is however not necessary to add products to stimulate bacterial development.

2. Never connect the rainwater or swimming pool drains to the unit. The water from these drains could disrupt the bacterial flora.

In case of storm or of heavy rains, a "flushing effect" could also flush out the sludge to a receiving body of water.

3. Don't forget to completely fill up the unit with clean water prior to any start-up or commissioning.

4. Once your Oxyfix® C-90 is installed, it is forbidden to carry out additional work that would affect the unit, unless otherwise advised by Eloy Water's engineering and design department.

3.2. Servicing

3.2.1. Regular servicing of the unit is a highly recommended means of monitoring the unit.

Each Oxyfix® C-90 is identified by a reference number on a nameplate inside the tank and on the housing of the blower (only for diaphragm blowers).

An identity card inserted inside a plastic pouch is provided with each Oxyfix® C-90 inside the **inlet pipe** of the unit. To retrieve it, you simply need to remove the red cap on the inlet pipe. Do not hesitate to **request this card from your installer** if you did not receive this identity card.

The card is printed with a number of check boxes that have to be ticked by the contractor or by the owner, including the box with the serial number shown on the nameplate. We invite you to return the completed document. You may also register your product on line at **www. eloywater.com**. Eloy Water or Eloy Water certified operator will then send you a Service Agreement.

Once the Service Agreement has been returned, Eloy Water (or or Eloy Water certified operator) :

- checks the agreement and enters it in its data bank ;
- sends a countersigned copy to the client ;
- files the agreement in a specific filing cabinet;
- targets a months for carrying out the first service action.

Recording the agreement in the data bank automatically generates a service schedule for your Oxyfix® C-90 unit. Eloy Water or its certified operator will then plan to service the unit and will send a card to the client advising him on which date the unit will be service.

The Servicing Report (section 6, appendix 1) sent to the client includes, general information and recommendations to get the best performance from your unit. It is important that you keep this report.

Whenever necessary, the source of any problem detected is specified and a quote to repair the unit if applicable is prepared.

Eloy Water has designed the Oxyfix® C-90 units with particular care to make sure that servicing the unit is both quick and convenient. To take full advantage of this feature, **it is essential to be able to readily access the manholes at any time and to reach inside any of the Oxyfix® C-90's compartments.**

3.2.1. A Service agreement will guarantee that your unit is properly maintained

Eloy Water or its approved operators will systematically propose a **service contract** to owner's of a new unit refer to section 6, appendix 1). In doing so, , Eloy Water can keep on file (updated in real time) a record of all the Oxyfix® C-90 sold and installed.. This file contains all the useful data needed to monitor each unit..

All of the tasks listed below are carried out when servicing an **Oxyfix® C-90 MB 1-1-4 EP, 5 EP 6 EP, 7EP, 8-9 EP, 10-11 EP, 12-14 EP, 15-17 EP or 18-20 EP**. These tasks are carried out at different times and by an approved operator.

Reference	Tasks
(Bis)annual basis	
1.	Opening and cleaning (if necessary) of the lids
2.	Control of the airlift, mud and foam
3.	Measurement of the sludge level in the primary compartment
4.	Measurement of the grease height in the primary compartment
5.	Control of the bubbling
6.	Control of the airtightness of the pipes and seals
7.	Vérification de la turbidité de l'eau du clarificateur.
8.	Replacement / cleaning of the filter (MB blower)
9.	Measurement of the pH ans temperature in the reactor
10.	Measurement of dissolved oxygen rate inside the reactor
11.	Taking pictures (if necessary)
Variable frequency	
12.	Replacement / cleaning of the filter (MB blower)
13.	Emptying the sludge

There are different types of service contracts which can include all or part of the service actions described above.. Please contact Eloy Water or the Approved Operator in your area to discuss a Service Contract that is most suitable to your needs.

Should you decide not to enter into a Service Agreement with Eloy Water or with an Approved Operator, it will be necessary in order for you to enjoy the performance guarantee, to carry out a yearly service on your Oxyfix® C-90 in compliance with the tasks described above.. To this end, Eloy Water may request that you provide some proof that these maintenance operations have actually been carried out..

A follow-up table to monitor your unit is also available in section 6, appendix 2, and must be completed by a maintenance service provider or by yourself..

Tasks 1, 2, 5, 6, 8, 11 et 12 can be carried out by the user as long as the user complies with all the health and safety regulations and provided that he has the necessary knowledge and equipment to do so (sludge blanket level probe, oxygen sensor, flasks and bottles,...). Nevertheless, we strongly recommend to use a maintenance service provider to carry out all of the maintenance tasks (in particular for tasks 3, 4, 7, 9, 10 et 13).

3.3. Emptying the sludge

The primary decanter of your Oxyfix® C-90 unit stores the "primary sludge" which is a build-up of the suspended solids contained in the waste water decanting at the bottom of the tank. The frequency at which the sludge needs to be removed depends largely on the rate at which the primary decanter is filled with waste water.

We recommend that you empty the tank when the primary decanter of your Oxyfix® C-90 is 70% full.

The frequency recommended for emptying the unit is indicative only and depends on a large number of factors such as the characteristics of the raw sewage to be treated, the life style of the users, the annual consumption of water, the servicing frequency of the unit, etc. It's therefore difficult to predict exactly how often you will need to empty the unit.

However and according to a **study carried out under a rated load of 3m³/day** using an organic load of 1.2 kgO₂/day, the sludge produced by an **Oxyfix C-90 18-20 EP** est estimated to be 0.120 m³/year/EP, i.e. a « theoretical » emptying frequency of every 21 months.. On this basis,, the emptying frequency for the Oxyfix® C-90 1 to 99EP units under standard working conditions can be estiamted as follow :

Models	Frequency of tank emptying	Models	Frequency of tank emptying
Oxyfix® C-90 MB 4 PE(1)	41 months	Oxyfix C-90 MB 8-9 PE(2)	40 months
Oxyfix® C-90 MB 5 PE(1)	42 months	Oxyfix C-90 MB 10-12 PE(2)	30 months
Oxyfix® C-90 MB 6 PE(1)	34 months	Oxyfix C-90 CB 13-14 PE(2)	26 months
Oxyfix® C-90 MB 7 PE(2)	42 months	Oxyfix C-90 CB 15-17 PE(3)	25 months
Oxyfix C-90 CB 21-27 PE(2)	24 months	Oxyfix C-90 CB 59-75 PE(3)	13 months
Oxyfix C-90 CB 28-38 PE(3)	17 months	Oxyfix C-90 CB 76-99 PE(3)	13 months
Oxyfix C-90 CB 39-58 PE(3)	17 months		

The waste collection company selected shall use appropriate equipment and comply with all the safety measures in effect to empty your Oxyfix® C-90.

The operator shall keep a minimum distance of 3 meters between the sewer cleaning truck and the centre of the manhole.

Only the primary decanter will need to be emptied. If required and at the request of a qualified technician, the other compartments may also have to be emptied.

Please follow the following procedure when emptying the tank:

1. Disconnect the blower
2. Open the primary decanter manhole opening
3. Pump out the "solid crust" floating on top of the primary decanter.
4. Completely empty the primary decanter *
5. Fill the unit with water from the house or from a garden hose until the water flows out of the biological reactor;
6. Plug-in the blower
7. Check that the unit works properly
8. Close the manhole covers.

* The single tank units are fitted with stainless steel partitions (1-4, 5 and 6 EP), the clarifier and the biological reactor are also partially emptied when emptying the primary decanter. This means that the volume emptied will total approximately 3m³ for the 4500 litre tank and 4m³ for the 6000 litre tank.

3.4. Sampling the treated water

Samples can easily be taken from the clarifier of the Oxyfix® C-90, without interfering with the operation of the unit, where a PVC Tee fitting has been designed for this purpose :



Fig 6a : Sampling Tee fitting inside an **Oxyfix® 1-4,5 or 6 PE unit**



Fig 6b : Sampling Tee fitting inside an **Oxyfix® 7,8-9,10-12,13-14,15-17,18-20 ou 21-27PE unit**



Fig 6c : Sampling Tee fitting inside an **Oxyfix® 28-38,39-58,59-75 ou 79-99PE unit**

As an option, a manhole can also be placed downstream of your station to harvest, control and allow the sampling of treated water. Sampling is usually done by the technician responsible for the maintenance of the treatment plants by means of a device specially designed for optimal sampling.

The sampling method and tools are available upon request at support@eloywater.com.

In the event of regulatory control of the installation, a 24-hour sampling can be performed in the clarifier's sampling tee safely and without impairing operation. To do this, simply place the programmable automatic sampler strainer inside this tee.

 For both types of sampling, it is imperative not to disturb the clarifier during the sampling sequence so as not to resuspend particles that may have developed on the walls of the sampling tee.

3.5. Procedure in case of malfunction

The following early warning signs may reveal possible malfunctions of the unit:

- Noticeable odours near the unit.
- Blocked drainage of untreated sewage inside the building.
- Discharge of untreated sewage inside the building.
- Unsatisfactory water quality at the outlet.

In the event where signs of a malfunction were noticed, the first thing to do is to check if the unit was properly installed. Indeed, a unit which has not been installed in accordance with the instructions specified by Eloy Water is likely to malfunction both mechanically and hydraulically.

Other malfunctions may also occur where the operating instructions are not complied with, for example:

- The use of toxic substances such as bleach, detergent, antibiotic,
- Insufficient maintenance.

In case of a malfunction, please contact the distributor of your country for advice and find his contact details on our web site at www.eloywater.com. Your distributor will then contact Eloy Water's after-sales service (maintenance@eloywater.com) in order to fully diagnose the problem.

3.6. Replacement of wear parts

The used parts should be dropped-off at an eco-centre or at a recycling centre in order to reduce any risk to the environment.

The following parts should be replaced or cleaned :

3.6.1. *Air filter of the blower*

The air filter must be checked and cleaned during each service or repair action. The filter is usually replaced yearly.

- This spare part is readily available in stock from our factory or from your distributor.

3.6.2. *Blower diaphragms (only for the Oxyfix® C-90 4 to 27 PE units)*

In the majority of cases, the blower diaphragms must be replaced every 2 years.

- These diaphragms are readily available in stock from our factory or from your distributor.

3.6.3. Fine bubble air diffusers

The Oxyfix C-90 are fitted with, "fine bubble" air diffusers (micro perforated membrane) that ensures a total oxygenation of the waste water.

Air diffusers only need to be replaced if they are damaged.

- These diffusers are readily available in stock from our factory or from your distributor.

Threaded sockets (3/4 inch) fitted to the air distribution piping system allow to easily assemble and replace the air diffusers.

In the event of a problem, the air diffusers can be quickly replaced by identical ones. The technicians proceeds as follow:

1. disconnects the air supply
2. empties the unit
3. dismantles the top grating out of the biological reactor
4. removes the bags containing the Oxybees
5. dismantles the lower grating which sits above the air diffusers
6. unscrews the defective air diffuser(s)
7. replaces the air diffuser(s)
8. secures the lower grating
9. puts the bags containing the Oxybees back in place
10. secures the top grating
11. starts the Oxyfix C-90 and checks the air supply

3.6.4. Media (Oxybee)

The media (Oxybee) is made from an unalterable and specially designed material that will not clog when used as specified in our user manual (sludge emptying frequency, polluting loads, etc.). Consequently, it never needs to be replace.

In the event where the media gets clogged up due to a non-compliant use or practice, it can easily be replaced by following this procedure:

1. disconnects the air supply
 2. dismantles the top grating out of the biological reactor
 3. removes the bags containing the Oxybees
 4. puts new bags of Oxybees back in the reactor
 5. secures the top grating
 6. starts the Oxyfix C-90 and checks the air supply
- These media are readily available in stock from our factory or from your distributor.

4. A few tips

So that your Oxyfix® gives you full satisfaction, please follow the following instructions:

- The treatment process used by the Oxyfix® C-90 resorts to living micro-organisms. Wherever possible please try not to perturb or to disrupt the process by avoiding to discard harmful substances in your Oxyfix® (**bactericides, bleach, solvents, pesticides, antibiotics, hydrocarbons, ...**). Household cleaning products may be used within the limits of the manufacturer's recommendation. It is however not necessary to add products to stimulate bacterial development. (enzymes, activators,...)
- Never connect the rainwater drains to the unit. In case of storm or of heavy rains, a "flushing effect" could also flush out the sludge to a receiving body of water.
- Don't forget to completely fill up the unit with clean water prior to any start-up or commissioning.
- Our servicemen in the field have recorded that, despite our advice and recommendations to the contrary, some owners unplug the blower of their Oxyfix C-90 over long periods of time. By doing this, they deprive the micro-organisms living in the Oxyfix® of oxygen. When this occurs, the biological reactor will switch to an "anaerobiosis" phase, which has the effect, in addition to the fact that the Oxyfix C-90 can no longer treat the waste water, to produce malodorous gases.
- Odours can also be smelled in case of an accidental shutdown of the blower (for example, during a simple power failure). These odours are not dangerous. They disappear as soon as the power comes back on. Should they persist, please contact without delay your distributor's after sales service.

5. Traceability

Each Oxyfix® C-90 is identified by a reference number on a nameplate inside the tank and on the housing of the blower (only for diaphragm blowers).

An identity card inserted inside a plastic pouch is provided with each Oxyfix® C-90 inside the **inlet pipe** of the unit. To retrieve it, you simply need to remove the red cap on the inlet pipe.

Do not hesitate to **request this card from your installer** if you did not receive this identity card.

The card is printed with a number of check boxes that have to be ticked by the contractor or by the owner, including the box with the serial number shown on the nameplate. We invite you to return the completed document in order to ensure the traceability of your product.

You may also register your product online at **www. eloywater.com**.

Filling out the identity card allows you to take advantage of an extended warranty on the tank and on the electromechanical components.

6. Warranties

Eloy Water guarantees that your Oxyfix® C-90, as it is described in this manual and provided that it is used normally and that it is properly serviced, is designed to treat waste water in a manner that complies with the regulatory requirements in effect at the time of its installation.

This guarantee shall be valid provided that the station:

- has been correctly sized (characteristics of the influent),
- has been properly installed, connected and commissioned,
- is used normally,
- is regularly serviced by our company.

The concrete tank housing your Oxyfix® C-90 is guaranteed for **10 years** provided that the instructions to install it, to put it into the ground and subsequent use are strictly adhered to.

A **2 year** warranty is issued covering all the electromechanical parts of the water treatment station under normal operating and installation conditions.

 Register your Oxyfix® C-90 in the Eloy Water data bank (by sending the identity card of the product duly completed or on line at www.eloywater.com) within 6 months of commissioning and **benefit from an extended warranty of 5 years** on the tank and **one year** on the electromechanical parts.

7. Service Guide Appendices

Appendix 1 Example of a Service Check Sheet (with service agreement)



Servicing contract
Specific terms of sales

Oxyfix® NZ C-90 MB 8 PE

Contract Number: 633055 - 20140415

PARTIES' DETAILS

1. Customer information

Last name:	First name:
Address:	ZIP code:
N°:	
City:	
State:	
Phone:	Cell phone:
e-Mail:	
Favourite visit day:	

2. Product information

Address (if different):	ZIP code:
N°:	
City:	
State:	

CONTRACT DETAILS

Tasks	Basic contract
Recording of inhabitant number and last emptying date	✓
Control of the blower	✓
Opening and cleaning (if necessary) of the lids	✓
Control of the airlift, mud and foam	✓
Measurement of the sludge level in the primary compartment	✓
Measurement of the grease height in the primary compartment	✓
Control of the bubbling	✓
Control of the airtightness of the pipes and seals	✓
Replacement / cleaning of the filter (MB blower)	✓
Measurement of the pH, dissolved oxygen rate and temperature in the reactor	✓
Control of the pump in the last compartment	✓
Taking pictures (if necessary)	✓
Writing visit report	✓
Period	1 year
Number of visit(s)	1 / year
Price Taxes excl.	240 \$
GST	15 %
Price Taxes incl.	276 \$

By signing below the Parties agree to be bound by the terms of this contract.
Date

Customer's signature:

Eloy Water Signature:

Eloy Water - www.elaywater.com
v20140414

Validity: 31/12/2014

Appendix 2 Example of a Service Check Sheet (without a service agreement)

<u>Type of unit (Equivalent Persons):</u> <u>Serial Number:</u> <u>Date Commissioned:</u> <u>Owner's Name:</u>				
Year	Tank emptying	Nature of service actions	Date	Signature
1 :				
2 :				
3 :				
4 :				
5 :				
6 :				
7 :				
8 :				
9 :				
10 :				
11 :				
12 :				
13 :				
14 :				
15 :				
16 :				
17 :				
18 :				
19 :				
20 :				

II. Installation manual

Submerged Aerobic Fixed Film Technology

Oxyfix® C-90 Range (1 to 99 PE)



1. Implementation and installation

1.1. Location

The Oxyfix® C-90 must be installed in a location:

- ideally where the distance between the blower and the unit is less than 20 metres ;
- outside a trafficable area for the Oxyfix® C-90 15-17 et 18-20 PE (*) and outside a trafficable area used by vPEicles **heavier than 3,5 T** for any other Oxyfix C-90 Unit (**);
- which is not likely to flood (***)
- which is accessible for servicing and for emptying the tanks.

(*) For any Oxyfix® C-90 unit having a 7.5m³ tank, used in a trafficable area or where the backfill is thicker than 20 cm, please provide for a concrete topping slab on top of the tank. No traffic or static load shall be authorised within 2.85 metres from the unit.

(**) For any Oxyfix® unit having a 4.5, 6, 10, 15 or 20m³ tank, used in a trafficable area for vPEicle of more than 3.5 tonnes or where the backfill thickness is greater than 80 cm, please provide for a concrete topping slab on top of the tank.

(***) In cases where the ground is wet, it is recommended to design and to provide for a ballast slab on top of the tank or an anchoring slab under the tank (please refer to section 1.10 of the installation manual).

1.2. Topographical and Discharge Conditions

- Sewage is fed to your Oxyfix C-90 through an inlet placed at the top of the tank and the treated water is discharged from an outlet also placed at the top of the tank. The difference between the inflow level in Compartment 1 and the outflow level in Compartment 3 is only 2 to 4 cm depending on the model of your Oxyfix C-90.

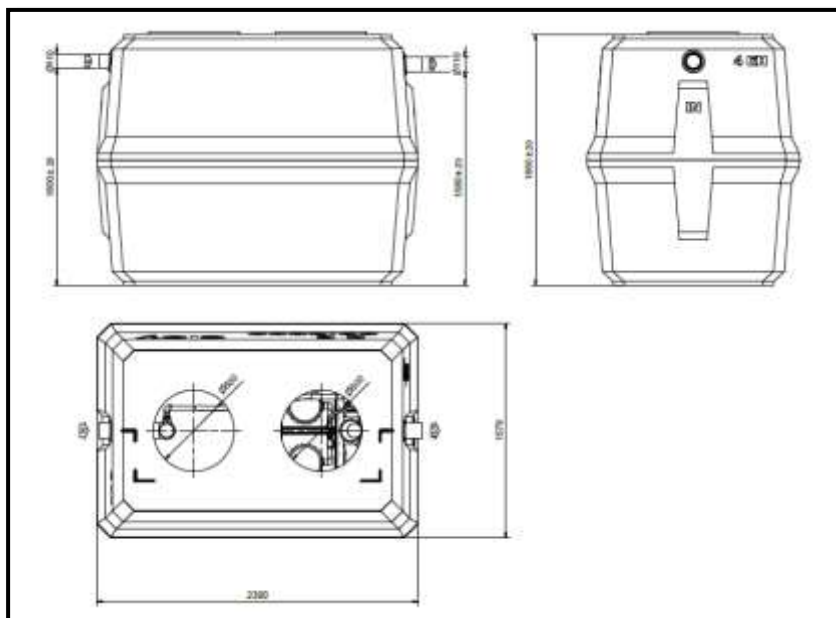

Fig-7 : Dimensional drawing of the Oxyfix C-90 MB 1-4 PE (1)

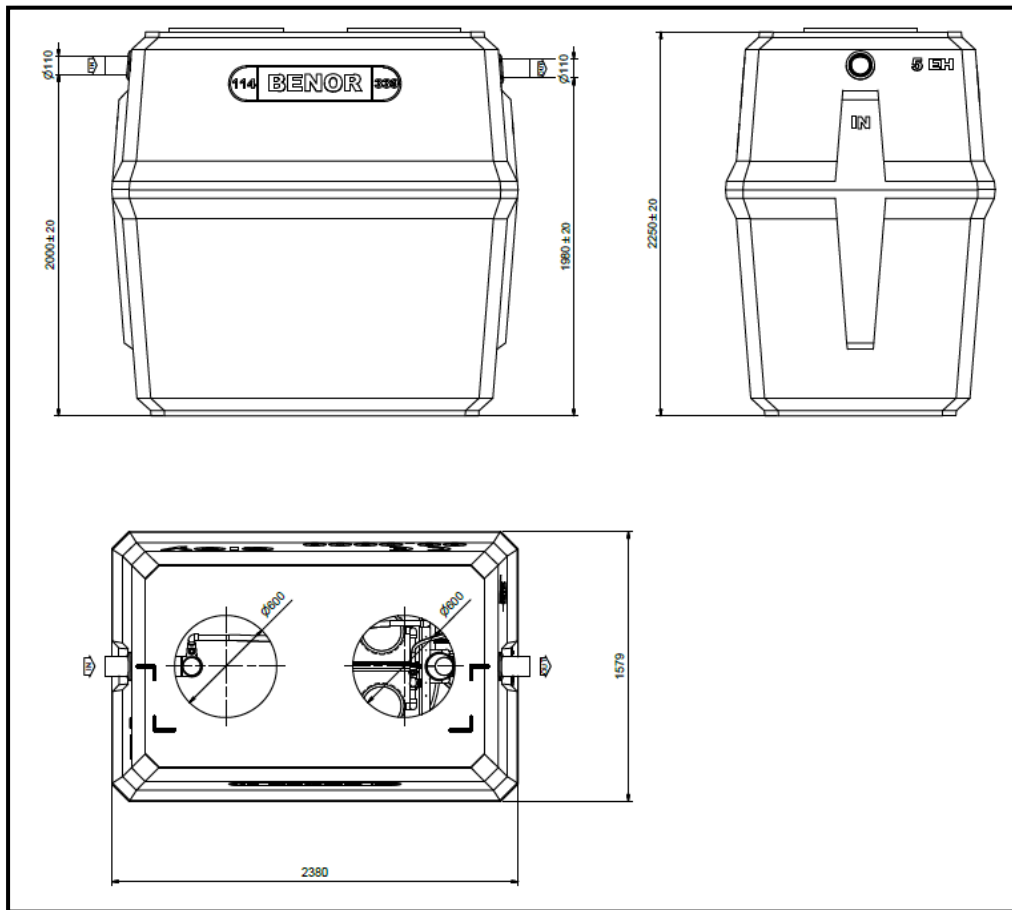

Fig-8 : Dimensional drawing of the Oxyfix C-90 MB 5 et 6 PE

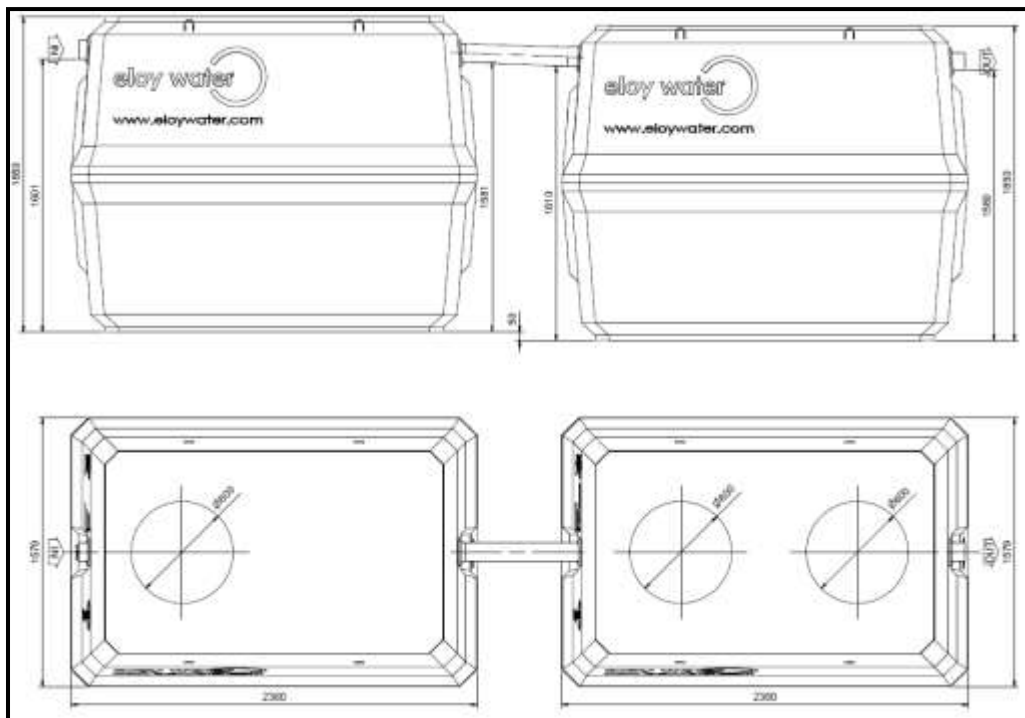

Fig-9 Dimensional drawing of the Oxyfix® C-90 MB 7 PE

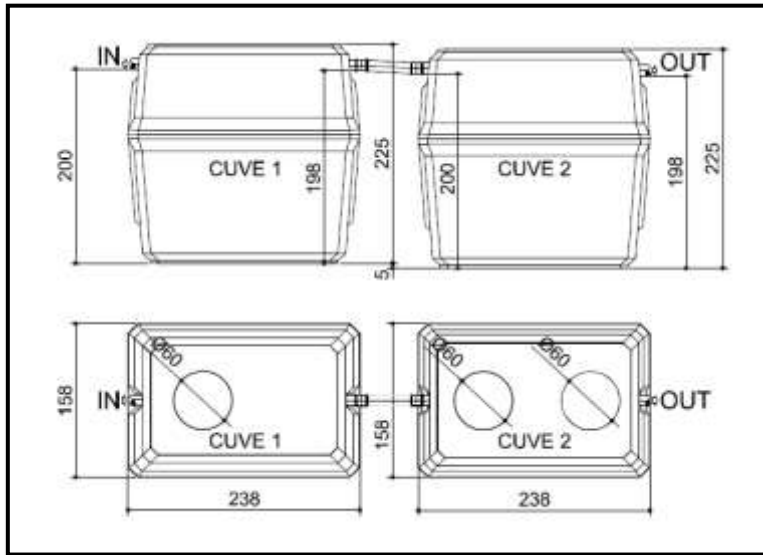

Fig-10 : Dimensional drawing of the Oxyfix® C-90 MB 8-9, 10-12 et 13-14 PE

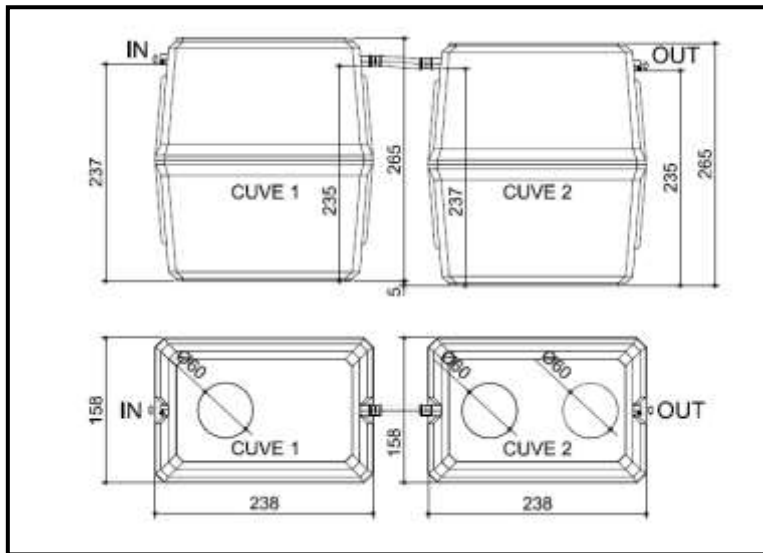

Fig-11 : Dimensional drawing of the Oxyfix® C-90 MB 15-17 et 18-20 PE

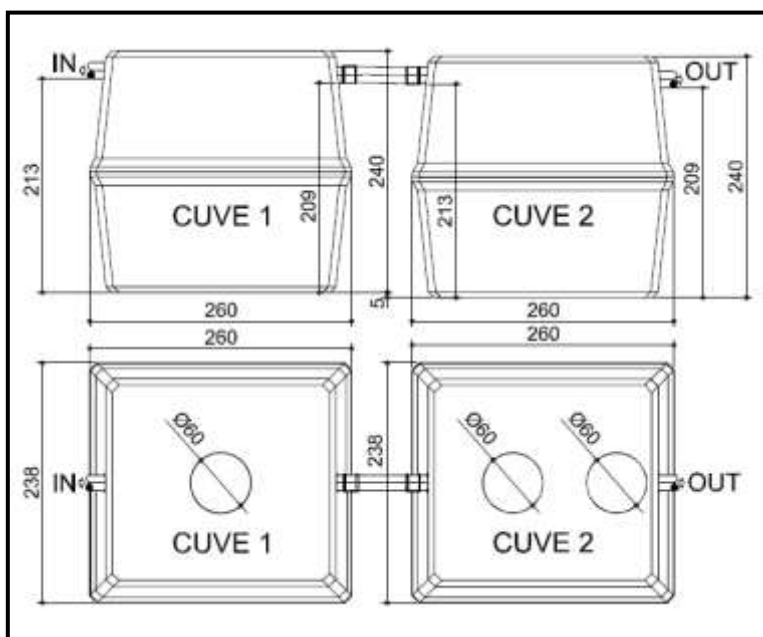

Fig-12 : Dimensional drawing of the Oxyfix® C-90 MB 21-27 PE

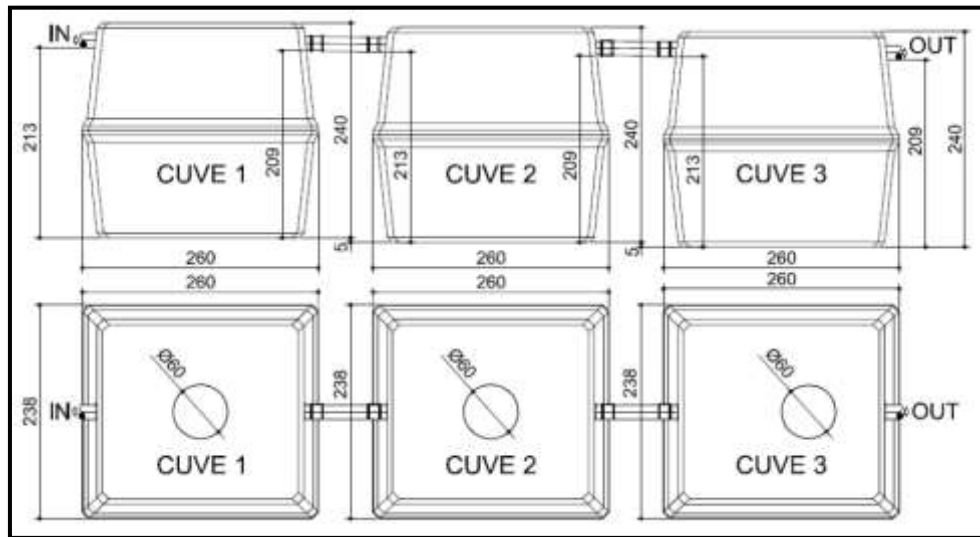

Fig-13 : Dimensional drawing of the Oxyfix® C-90 CB 28-38 PE

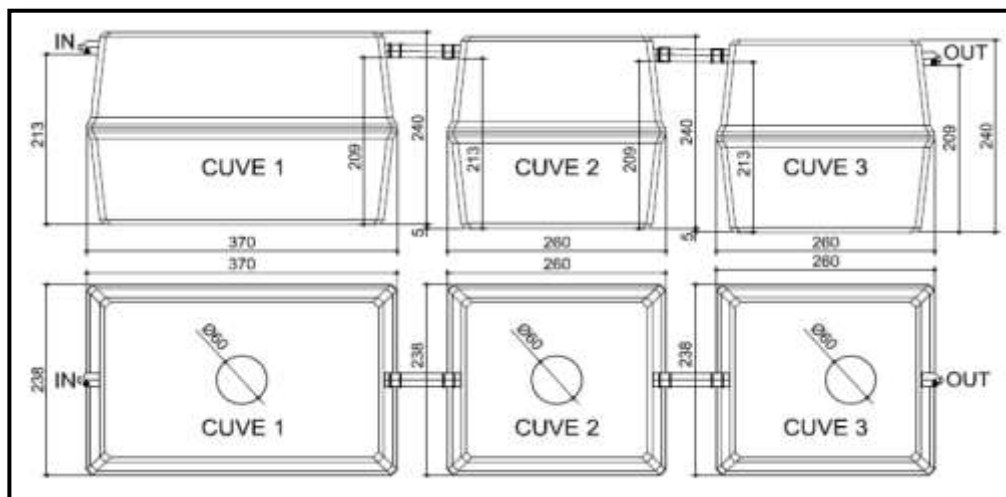

Fig-14 : Dimensional drawing of the Oxyfix® C-90 CB 39-58 PE

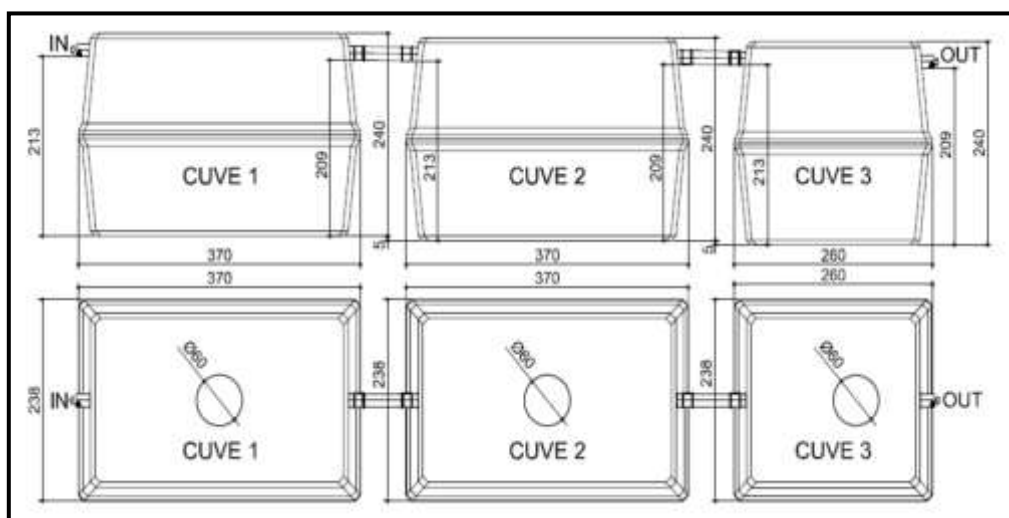

Fig-15 : Dimensional drawing of the Oxyfix® C-90 CB 59-75 PE

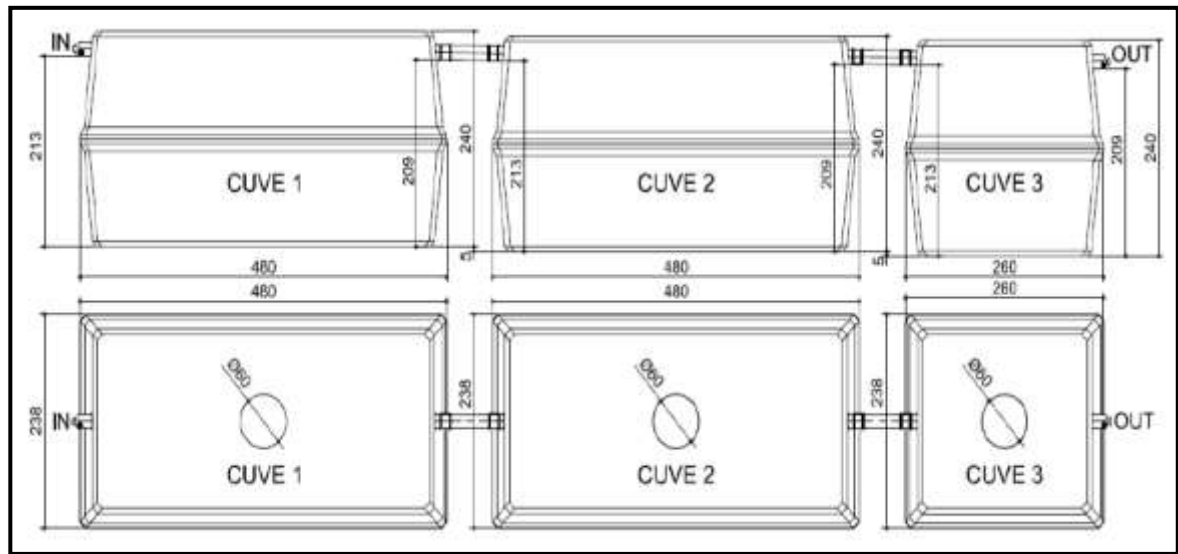

Fig-16 : Dimensional drawing of the Oxyfix® C-90 CB 76-99 PE

- The treated water may be discharged in a storm drain, water streams (creeks, rivers,...), a drainage field (designed according to the soil water index, in a tertiary treatment facility (lagoon), (lagunage),...
- When discharging into a drainage field, special care shall be taken in order to avoid any clogging of the pipes by installing a filter.
- Discarding inappropriate substances with the influent can disrupt or curb the water treatment process. Do not discard noxious substances in the unit ((bacteriocides, bleach, solvents, pesticides, antibiotics, hydrocarbons,...).

In cases where the influent is fed from a pumping station into the Oxyfix® C-90 unit, make sure that the flow rate applied does not perturb the proper operation of the unit which would as a consequence impact on the quality of the effluent.

1.3. Transport

The Oxyfix® C-90 has the following characteristics:

OXYFIX® C-90 MB/CB RANGE															
Total PE connected	PE	1-4	5	6	7	8-9	10-12	13-14	15-17	18-20	21-27	28-38	39-58	59-75	76-99
Total tank 1 volume	m ³	4,5	6,0	6,0	4,5	6,0	6,0	6,0	7,5	7,5	10	10,0	15,0	15,0	20,0
Total tank 2 volume		-	-	-	4,5	6,0	6,0	6,0	7,5	7,5	10	10,0	10,0	15,0	20,0
Total tank 3 volume		-	-	-	-	-	-	-	-	-	-	-	10,0	10,0	10,0
<i>Overall Size tank 1</i>															
Length	m	2,38	2,38	2,38	2,38	2,38	2,38	2,38	2,38	2,38	2,60	2,60	3,70	3,70	4,80
Width	m	1,58	1,58	1,58	1,58	1,58	1,58	1,58	1,58	1,58	2,38	2,38	2,38	2,38	2,38
Height	m	1,85	2,25	2,25	1,85	2,25	2,25	2,25	2,65	2,65	2,40	2,40	2,40	2,40	2,40
<i>Overall Size tank 2</i>															
Length	m	-	-	-	2,38	2,38	2,38	2,38	2,38	2,38	2,60	2,60	2,60	3,70	4,80
Width	m	-	-	-	1,58	1,58	1,58	1,58	1,58	1,58	2,38	2,38	2,38	2,38	2,38
Height	m	-	-	-	1,85	2,25	2,25	2,25	2,65	2,65	2,40	2,40	2,40	2,40	2,40
<i>Overall Size tank 3</i>															
Length	m	-	-	-	-	-	-	-	-	-	-	2,60	2,60	2,60	2,60
Width	m	-	-	-	-	-	-	-	-	-	-	2,38	2,38	2,38	2,38
Height	m	-	-	-	-	-	-	-	-	-	-	2,40	2,40	2,40	2,40
Ø Inlet (IN) / Outlet (OUT)	m	110/ 110	110/ 110	110/ 110	110/ 110	110/ 110	110/ 110	110/ 110	110/ 110	110/ 110	160/ 160	160/ 160	160/ 160	160/ 160	160/ 160
Weight tank 1 (excl. pallet)	kg	3110	3260	3310	2500	2750	2750	2975	3200	3200	5750	5750	7500	7500	9100
Weight tank 2 (excl. pallet)	kg	-	-	-	2950	3325	3340	3350	3950	3975	6730	6120	6230	8360	10350
Weight tank 3 (excl. pallet)	kg	-	-	-	-	-	-	-	-	-	-	5820	5820	5820	5820
Manholes tank 1	cm	2 x Ø 60	2 x Ø 60	2 x Ø 60	1 x Ø 60	1 x Ø 60	1 x Ø 60	1 x Ø 60	1 x Ø 60	1 x Ø 60	1 x Ø 60	1 x Ø 60	1 x Ø 60	1 x Ø 60	1 x Ø 60
Manholes tank 2	cm	-	-	-	2 x Ø 60	2 x Ø 60	2 x Ø 60	2 x Ø 60	2 x Ø 60	2 x Ø 60	2 x Ø 60	1 x Ø 60	1 x Ø 60	1 x Ø 60	1 x Ø 60
Manholes Tank 3	cm	-	-	-	-	-	-	-	-	-	-	1 x Ø 60	1 x Ø 60	1 x Ø 60	1 x Ø 60

In cases where the tank is directly lowered in the ground using a crane truck.

The truck should be able to reach the site safely by a roadway wider or equal to 3.5 metres and capable of withstanding high tonnage vPEicles.

To safely get through the load requires a clearance height (free of any obstacle) of **4.5 meters**.

The **area around the excavation** shall be cleared completely over a **minimum width of 4 m** in order that the hydraulic outriggers can be lowered to stabilise the crane truck when unloading the tank.

Note: The installer shall be responsible for implementing all the safety measures that apply during the installation.

The tank is usually unloaded from **the back of the truck**. To achieve this, the centre to centre distance between the crane and the middle of the hole shall be no more than 6 metres.



Important remarks:

The preparatory work must be fully completed before the arrival of the delivery truck.

In cases where the tank is to be lowered in the ground by a crane already on site.

The **area around the excavation** shall be cleared completely over a **minimum width of 2 m** to make sure that the ground is sufficiently stable to unload the tank.

1.4. Handling the tank

Steps to follow for handling a tank :

- Unfold the crane and secure the slings.
- Please use four slings that have been certified by an accredited organisation and appropriate for the weight and dimensions of the tank (see table below). These shall be used at **an angle of between 60° and 90°**, and secured to the lifting lugs provided for this purpose.

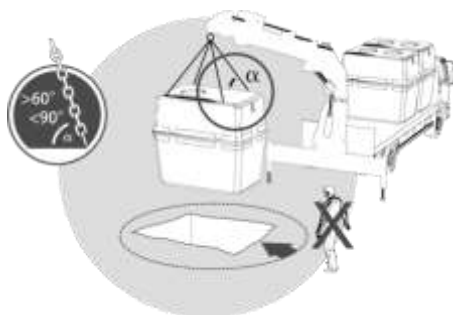

Fig-17: Handling the C-90 tank

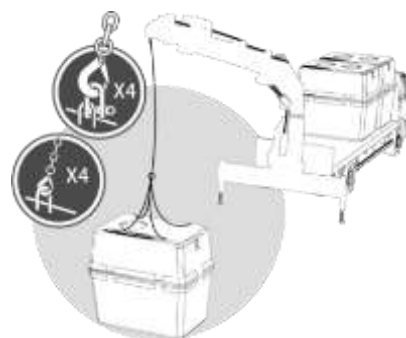

Fig 18: Handling the C-90 tank

Please select appropriate slings according to site conditions:

Oxyfix® C-90	Minimum length of the slings (m)	Load per sling (t)		
		Using crane truck	Unloading with a backhoe on levelled ground	Unloading with a backhoe on uneven ground
4 500L	1.7	0.9	1.7	3.5
6 000L	1.7	1	2	4
7 500L	1.7	1.2	2.4	4.7
10 000L	2	2	3.9	7.8
15 000L	2.8	2.4	4.8	9.7
20 000L	3	3	6	12

- Place the unit so that it is totally level on the ground. Once the tank is in place, check any difference in flatness. It should be less than 0.5 %.

⚠ The major safety measures to bear in mind are:

- It shall be absolutely forbidden to walk or circulate under the load.
- Only use a crane of a suitable lifting capacity and certified by an accredited organisation.
- Make sure the ground is stable before lowering the tank in place
- Make sure the tank is level
- Remove the slings from the hooks.

⚠ Storage:

If it is necessary to store the tank on site before it is finally lowered in the ground, please make sure that it rests on a stable and horizontal support like a pallet.

1.5. Excavation and lowering the unit in the ground

- All the applications and surveys conducted on the land site shall be carried out pursuant to the regulations in effect in order to assess the constraints linked to the nature of the ground.

⚠ Constraints related to the topography and to the nature of the land.

Please comply with the specific requirements that apply under the following circumstances:

Sloping land:

The excavation of the pad shall be carried out at ground surface.
Make sure not to place the tank at a lower level of the land.

Impervious soil :

In case where the soil is impervious ($K < 15$ mm/h) please consult a qualified geotechnical consultant in order to define if the water flowing out of your Oxyfix® C-90 will penetrate the soil at a sufficient rate or if it must flow out to a surface water system (outfall).

Water table :

Our concrete units can be installed in wetlands, or in the presence of groundwater (see section 1.10 of the installation guide). Installing the unit near a groundwater table is possible provided that the water table does not rise above the lower level of the excavation.

Depending on the local context and the level of water in the soil, a ballast slab may have to be laid over the tank (or an anchoring slab laid under the tank) if specified by the project manager or if suggested by the installer.

Flood declared areas:

It is strongly recommended not to install the unit in a flood declared area. In these cases, please consult a qualified consultant who will define the specific requirements for implementing the unit.

- The **depth** of the excavation is determined as follows: height of the tank and thickness of the backfill (max) + thickness of the sand bed (or equivalent)

Below please find the size and depth of the excavation recommended for each model :

Type	Length (cm)	Width (cm)	Height max (cm)		
			Excavation	Bed thickness	
Oxyfix® C-90 1-4 PE	340	260	265	+	10-20
Oxyfix® C-90 5 et 6 PE	340	260	305	+	10-20
Oxyfix® C-90 7 PE	630	260	265	+	10-20
Oxyfix® C-90 8-9, 10-12 et 13-14 PE	630	260	305	+	10-20
Oxyfix® C-90 15-17 et 18-20 PE	630	260	285	+	10-20
Oxyfix® C-90 21-27 PE	670	340	320	+	10-20
Oxyfix® C-90 28-38 PE	980	340	320	+	10-20
Oxyfix® C-90 39-58 PE	1090	340	320	+	10-20
Oxyfix® C-90 59-75 PE	1200	340	320	+	10-20
Oxyfix® C-90 76-99 PE	1420	340	320	+	10-20

 **The guarantee is operative only if the tanks are 100% buried.**

Note: the following minimum slopes must be observed :

- **2% of downward slope** for the hydraulic pipes
- **1% of upward slope** for the vent and air supply pipes.

 It is essential to build a stable, solid and perfectly levelled bedding under the concrete tank. The 10-20 cm sand bed (laid on dry soil) must also be well compacted. In certain instances the nature of the soil may be suitable and homogeneous enough and may not require the use of additional sand. In this case, please seek the advice of your geotechnical consultant.

⚠ It is essential to keep a minimum gap of **50 cm** between the tank and the walls of the excavation.

⚠ When installing two or three tank units, it is essential to keep a **minimum gap of 50 cm** between each tank and to lay the bedding in a step pattern as shown in figure 19.

⚠ When installing two tanks units, the height difference between the two tanks must be **100 mm max.**

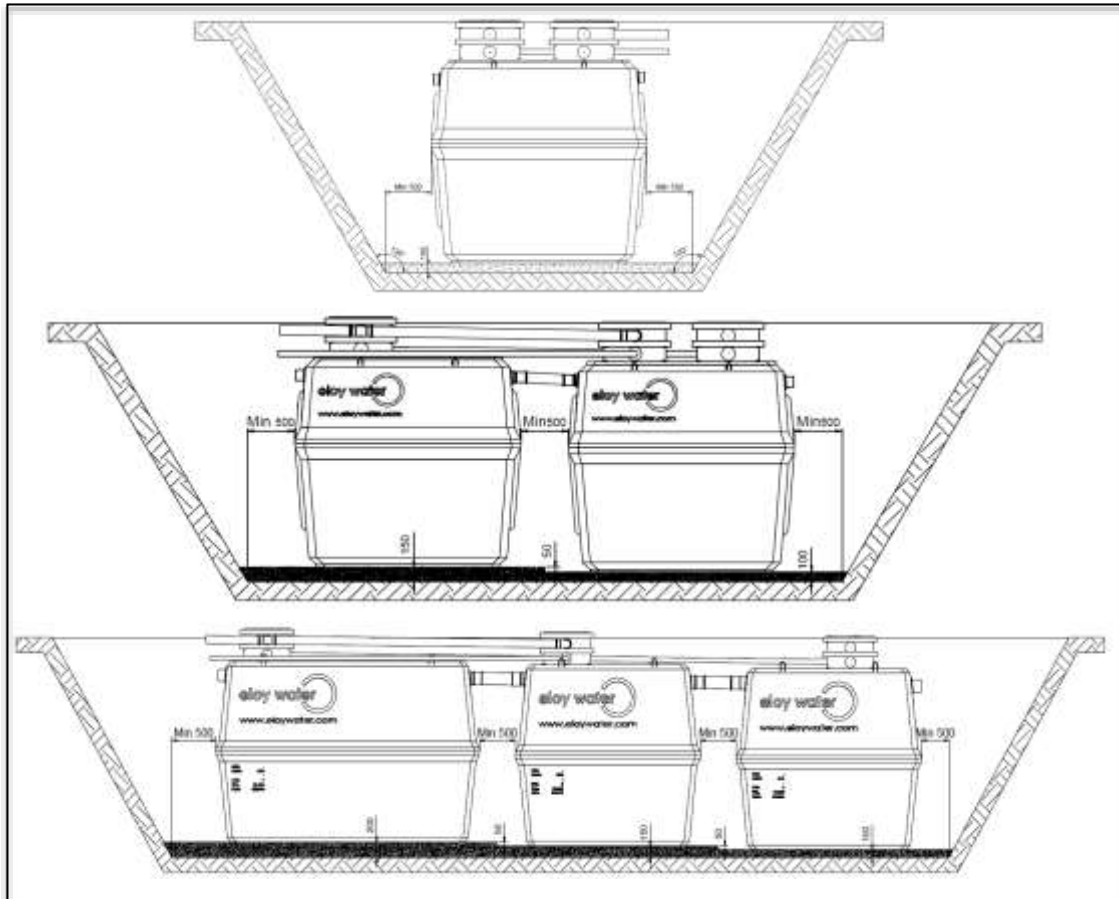

Fig-19 : Layout drawing of the unit

1.6. Backfilling

- ☑ Backfill the hole around the tank up to just below the **inlet and outlet connections** with material having a size distribution of 0 to 20 mm (sand, crushed stone, granules, etc.) or with the excavated soil provided it does not contain objects that could damage the tanks and that it **is sufficiently loose**.
- ☑ The use of a sand cement mixture for extra stability is recommended but not compulsory.



Fig-20: **Backfilling**



Fig-21: **Compact backfill**

- ☑ **Compact the backfill** with care (by increments of 50 cm). A poorly compacted backfill can cause the side of the tank to crack.

It is not recommended to do the compacting with a motor driven device.

1.7. Hydraulic Connection

Tank markings showing the inlet (IN) and outlet (OUT) indicate in which direction the water flows (hydraulic flow). The inlet and outlet shall be connected using socket connections and PVC or other 110mm diameter pipe for the Oxyfix® C-90 1-4 to 20 PE and with 160mm diameter pipe for the Oxyfix® C-90 21-27 to 76-99 PE.



Fig-22 : **Hydraulic connection**

Special care must be taken to ensure that the backfilled area around the inlet and outlet pipes is totally stable. Ideally, embed the pipes in a sand cement mixture of 50 kg cement /cu. m. sand as a minimum. It is imperative that the pipes are kept solidly in place in order to avoid any distortion that could occur later-on due to soil compaction.

In cases where the topography of the sites does not allow to comply with the required slope, it is preferable to use the natural slope by favouring the slope upstream of your unit. To provide for a better flow of the influent, a slope of 2% is required, whereas the treated effluent can flow using less slope.

Once the connection is completed, please check for leak tightness.

1.8. Vent pipe

The sedimentation of the raw sewage in the primary decanter (first compartment) of the Oxyfix® C-90 occurs in the presence of anaerobic bacteria (i.e. that does not need oxygen for growth). This phenomenon implies a release of methane, carbon dioxide and hydrogen sulphide which, combined in combination with the fumes of volatile fatty acids, can cause bad odours. These

heavy gases must be evacuated out to the atmosphere. This is the reason why it is essential to properly vent the Primary decanter.

The compartment storing the sludge must be fitted with a 100mm or with a larger diameter vent pipe, separated from the treated and rain water pipes and run sufficiently high above the roof line to dissipate all noxious smells.

The vent pipe shall rise steadily above the roof. Please limit the number of pipe bends and turns and the radius of curvature to 45 degrees. A cap should be placed on top of the vent pipe in order to avoid any accidental blockage.

This vent pipe runs from the biological reactor and the primary decanter and sufficiently high above the roof line where the outlet can be well exposed to the prevailing winds in order to extract and dissipate the heavy gases. The vent pipe should be inserted through a hole cut on the side of the cover risers as shown below.



Fig-23: Vent pipe fitted to a single tank Oxyfix® C-90 unit

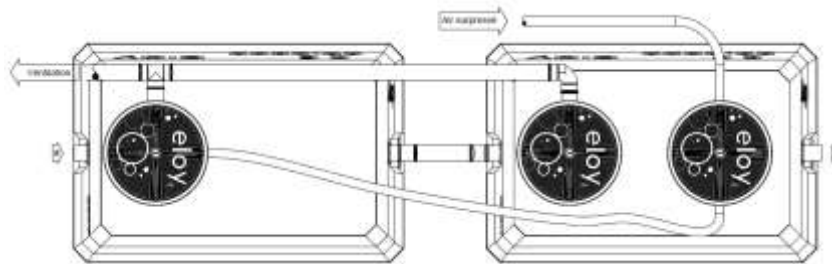



Fig-24: Vent pipe fitted to a two-tank Oxyfix® C-90 unit



Fig-25: Vent pipe fitted to a three-tank Oxyfix® C-90 unit

 Failing to vent the Oxyfix® C-90 unit may result in serious and irreversible deterioration of the concrete tanks, risers and of the cast iron covers due to a biogenic reaction.

1.9. Finishing

- ☑ Finish the backfilling operation using a material with a particle size distribution of between 0 and 6 mm (sand, small crushed stone, etc.) up to the base of the cover risers (tank fully covered).
- ☑ Finish with topsoil, or with removed soil. **The soil thickness above the** three openings of the tank must not be greater than 80 cm, i.e. a static load of + /- 1400 Kg/m². For the Oxyfix® C-90 15-17 and 18-20 PE, this soil thickness is 20cm, i.e. a static load of + /- 350 Kg/m².



Fig-26: Completing the venting system of a single, of a two or of a three-tank Oxyfix® C-90 unit.

Cover Risers :

To achieve backfills of 0 to 60cm in thickness, it is recommended to install 600mm diametre cover risers to ensure easy access to the different parts of the unit.

Where the backfill is thicker than 60 and 80cm, it is highly recommended to use square cover risers 80x80cm to ensure easy access to the different parts of the unit.

Thickness of soil layer :

A concrete topping slab will be required in cases where it is necessary to cover the unit with more than 0.8m (0.2m for Oxyfix® C-90 15-17 et 18-20 PE) of topsoil. It is mandatory to design and provide a topping slab on top of the tank. The concrete topping slab may where appropriate be subject to specific design requirements.

vPEicle traffic:

For those Oxyfix® C-90 units that are delivered complete with 7.5m³ tanks, and used in a trafficable area, it is imperative to design and provide a topping slab on top of the tank.

For the Oxyfix® C-90 units delivered with 4.5,6,10,15 et 20m³ tanks, and used in a trafficable area where vPEicles heavier than 3.5 tonnes circulate, it is imperative to design and provide a topping slab on top of the tank.

Please seek the advice from a qualified engineering consultant who will define the specific requirements according to the layout of the site and the nominal tonnage of the vPEicles likely to circulate on top of the unit.

Precaution before filling:

A tank could crack or even burst when filling it with water if you fail to backfill the tank first. It is therefore forbidden to fill a tank of water, even half-full, until it is completely backfilled all around and up to the level of the cover.

1.10. Installation under high water table conditions.

 In presence of high water table conditions, all the electrical materials have to be installed above ground.

Depending on the local context and the level of water in the soil, a ballast slab may have to be laid over the tank, or an anchoring slab laid under the tank if specified by the project manager or if suggested by the installer.

The following tables show the allowable depth of water in the excavation before a tank will float depending on the depth of the tank in relation to the natural level of ground surface and depending on the thickness of the backfill over the top of the tank.

In cases where there is a risk that the tank might float, please contact Eloy Water or a competent consultant to design a ballast or anchoring slab.

Tank with a man hole cover :

Tanks with one man hole	Allowable depth of water in the excavation before a tank will float depending on the depth at which the tank is installed				
	Thickness of backfill on top of the tank (18 kN/m ³)				
	0 cm	20 cm	40 cm	60 cm	80 cm
C-90 4500L	71 cm	97 cm	123 cm	149 cm	176 cm
C-90 6000L	80 cm	106 cm	132 cm	158 cm	184 cm
C-90 7500L	94 cm	120 cm	146 cm	172 cm	198 cm
C-90 10000L	96 cm	125 cm	154 cm	183 cm	212 cm
C-90 15000L	86 cm	117 cm	147 cm	177 cm	207 cm
C-90 20000L	80 cm	111 cm	141 cm	172 cm	203 cm

Tanks with one man hole	Allowable depth of water in the excavation before a tank will float in relation to the natural level at ground surface.				
	Thickness of backfill on top of the tank (18 kN/m ³)				
	0 cm	20 cm	40 cm	60 cm	80 cm
C-90 4500L	114 cm	108 cm	102 cm	96 cm	89 cm
C-90 6000L	145 cm	139 cm	133 cm	127 cm	121 cm
C-90 7500L	171 cm	165 cm	159 cm	153 cm	147 cm
C-90 10000L	144 cm	135 cm	126 cm	117 cm	108 cm
C-90 15000L	154 cm	143 cm	133 cm	123 cm	113 cm
C-90 20000L	160 cm	149 cm	139 cm	128 cm	117 cm

Tanks with two man holes :

Tanks with two man holes	Allowable depth of water in the excavation before a tank will float depending on the depth at which the tank is installed				
	Thickness of backfill on top of the tank (18 kN/m ³)				
	0 cm	20 cm	40 cm	60 cm	80 cm
C-90 4500L	71 cm	90 cm	110 cm	129 cm	149 cm
C-90 6000L	80 cm	99 cm	118 cm	137 cm	157 cm
C-90 7500L	94 cm	113 cm	133 cm	151 cm	170 cm
C-90 10000L	96 cm	121 cm	146 cm	171 cm	196 cm
C-90 15000L	86 cm	114 cm	141 cm	169 cm	196 cm
C-90 20000L	80 cm	108 cm	137 cm	166 cm	195 cm

Tanks with two man holes	Allowable depth of water in the excavation before a tank will float in relation to the natural level at ground surface.				
	Thickness of backfill on top of the tank (18 kN/m ³)				
	0 cm	20 cm	40 cm	60 cm	80 cm
C-90 4500L	114 cm	115 cm	115 cm	116 cm	116 cm
C-90 6000L	145 cm	146 cm	147 cm	148 cm	148 cm
C-90 7500L	171 cm	172 cm	172 cm	174 cm	175 cm
C-90 10000L	144 cm	139 cm	134 cm	129 cm	124 cm
C-90 15000L	154 cm	146 cm	139 cm	131 cm	124 cm
C-90 20000L	160 cm	152 cm	143 cm	134 cm	125 cm

1.11. Sludge recirculation connection

1.11.1. Oxyfix® C-90 1-4 to 6 PE

The Airlift is pre-fitted by Eloy Water in the Oxyfix® C-90 unit.

1.11.2. Oxyfix® C-90 7 to 21-27 PE







Once your unit is properly installed, the air supply hose to the airlift needs to be connected (supplied with the unit) in order to recirculate the sludge from the clarifier back to primary tank.

This flexible hose shall be inserted in a sheath of **100 mm minimum**, in order to avoid any damage (crushing or tearing) likely to impact on the proper aeration of the Oxyfix® system. The hose is connected to the airlift in the clarifier and to the water break nozzle in the primary tank with screwable barb fittings.

To do this, you will require :

- 1 X 100 mm minimum diameter protective sheath (not supplied).
- 2 X Forsheda thin EPDM V-rings adapted to the diameter of the sheath (not supplied)
- 1 X drill + Holesaw matching the outside diameter of the Forsheda ring (Not supplied)

Operations that must be carried out :

1. Drill out the port holes from the lower rise.	
2. Once drilled, insert the seals in the port holes.	
3. Insert the recirculation pipe inside its protective sheath and connect it to the relevant devices in the primary decanter and in the clarifier.	
<p>4. Pull the recirculation pipe into the sheath and connect it.</p> <p>4a. Remove the protection (sticker) from the airlift PVC pipe (clarifier) and from the IN PVC pipe (decanter).</p> <p>4b. Make sure the gum ring has not been removed as well.</p> <p>4c. Connect the recirculation pipe to the airlift PVC pipe in the clarifier compartment.</p>	  

<p>5. Connect the recirculation pipe to the IN PVC pipe in the decanter compartment.</p> <p>Recirculation must be between 0.42 and 0.69 liters per minute per population equivalent. For example, the Oxyfix C-90 9PE must recirculate between 3.78 and 6.21 liters per minute.</p>	
---	---

 In order to ensure that your airlift operates properly, it is essential to :

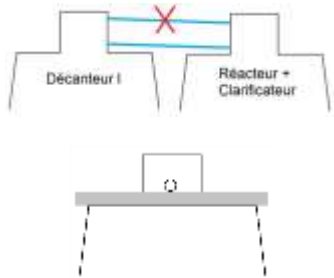
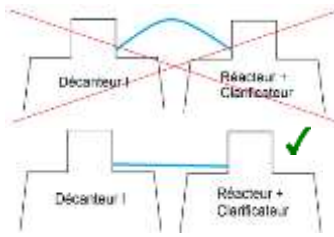
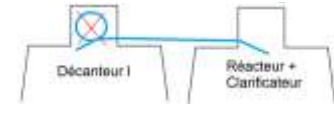
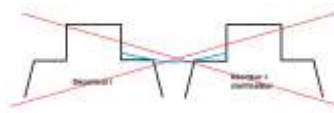
<p>1. Pass the recirculation pipe through the port holes on the cover riser located nearest to the tank cover.</p> <ul style="list-style-type: none"> • When using polyethylene cover risers, the height measured between the centre of the port hole and the top of the tank must not be greater than 85mm for the 200 mm cover risers and greater than 93mm for the 300 mm cover risers. • If a ballast or a trafficable concrete topping slab is used, the lower point of the port hole must be flush with the slab. 	
<p>2. Take care when connecting the recirculation pipe to keep it as straight as possible in order to avoid any changes in the direction of the flow.</p>	
<p>3. If necessary, shorten the recirculation pipe by cutting it to a suitable length in order to limit any head losses.</p>	
<p>4. Avoid reversed slopes and low points.</p>	

1.11.3. Oxyfix® C-90 28-38 to 76-99 PE





Once the unit is properly installed, you need to connect the hose from the recycling pump (provided with the unit) which recycles the solution from the clarifier back to the primary tank.

This flexible hose shall be inserted in a sheath of **90 mm minimum**, in order to avoid any damage (crushing or tearing) likely to impact on the proper aeration of the Oxyfix® system.

To achieve this, you will require :

- 1 X 90 mm minimum diameter protective sheath
- 2 X Forsheda thin EPDM V-rings adapted to the diameter of the sheath
- 1 X drill + Holesaw matching the outside diameter of the Forsheda ring

Operations that must be carried out :

<p>1. Drill out the port holes on the cover riser located nearest to the tank cover.</p>	
<p>2. Once drilled, insert the seals in the port holes.</p>	
<p>3. Insert the recycling hose in its protective sheath and connect it to the recycling pump using the quick coupling. Then place the pump back at the bottom of the clarifier.</p>	
<p>4. Connect the other end of the hose with the quick coupling to the break nozzle in the primary tank.</p> <p>If necessary, shorten the recirculation pipe by cutting it to a suitable length.</p>	
<p>5. Electrically connect the recycling pump.</p>	<p>See schemes provided with the panel.</p>

1.12. Blower connection to Oxyfix C-90®

The blower can be located up to a distance of 20 meters from the unit. The hose is slip-fitted on the end-piece of the blower and secure with the supplied collars. The flexible tubing shall be inserted in a sheath :

- of 60 mm minimum for Oxyfix C-90 1-4 to 21-27 PE,
- of 90 mm minimum for Oxyfix C-90 28-38 to 76-99 PE,

In order to avoid any damage (crushing or tearing) likely to impact on the proper aeration of the Oxyfix® system: Care shall be taken to connect the blower to the water treatment station so that the tubing is as straight as possible in order to avoid any changes in direction and curvatures (max. 45 degrees).

⚠ It is essential to install the blower in a clean, dry, temperate and properly ventilated utility chamber. To avoid the blower from overheating, it is recommended to place it in a utility chamber having a minimum volume of 0.08 m³, fitted with enough ventilation intakes to ensure sufficient and efficient ventilation and cooling of the motor.

Good ventilation would involve at least a 63mm diameter air inlet at the lower part of the chamber and another 63 mm diameter air inlet at the top opposite side of the chamber. Forced air circulation may also be used if necessary.

⚠ In cases where the blower requires to be fitted inside a **buried utility chamber**, please take all the necessary precautions to **ensure that the utility chamber is totally water tight**. In any event, a device to drain the water from inside the box shall be fitted.

⚠ Make sure to place the blower above the water level. Installing the blower below the water level could create a situation whereby some water would get siphoned inside the blower should it stop. The siphoned water would consequently flood the electromagnetic parts of the blower and cause a leak, a short circuit or an electric shock.

1.12.1. Diaphragm blowers (Oxyfix® C-90 1-4 to 21-27 PE)

The blower is connected to the quick coupler located on the air supply line with a flexible hose (provided with the unit).

Warning, The red cap on the quick coupler must be removed before you attempt to connect the hose.

This hose is also inserted on the outlet of the blower and secured with a hose clamp..



Fig-27 : Connection on the biological reactor side



Fig-28 : Connection to the blower .

For the Oxyfix® C-90 1-5 and 6-7 PE, to assure air tightness between the blower and the air intake hose, place a rubber end-piece (provided with the Oxyfix® C-90) on the outlet of the blower following the procedure given below :

1. Place the rubber end-piece (provided in the plastic bag) on the outlet of the blower so that 2 mm protrudes out, as shown on the photo.
2. Pass the collar (provided in the plastic bag) over the pipe and push the blue pipe over the entire end-piece of the blower. This will force the end-piece flush with the blower.
3. Place the collar so that the steel rings are inside the ribs of the hose and tighten.
4. Connect the blower and check the air tightness



1.12.2. Side channel blowers (Oxyfix C-90® 38 to 99 PE)

The blower is connected using a quick coupler fitted to the air supply line of the unit using a flexible hose (provided with the unit)

The hose is also connected to the blower using a similar quick coupler. A detailed procedure for assembly is provided with the blower.

If necessary, shorten the flexible hose by cutting it to a suitable length.

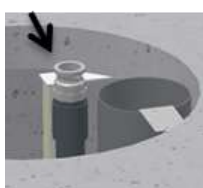

Fig-29 : Connection to the air supply line



Fig-30 : Hose



Fig-31 : Connection to the blower

1.13. Electrical connection

- Check if the existing electrical installation is adequate to connect the blower (proper current and power ratings, equipotential bonding - earthing - and if the ohmic value complies with the Electrical Installations standards of your country).

Model	Blower voltage rating (Volts)	Blower power rating (kW)	Pump voltage rating (Volts)	Pump power rating (kW)	Frequency (Hz)
Oxyfix® C-90 4 PE	1x230	0,06	-	-	50
Oxyfix® C-90 5 PE	1x230	0,06	-	-	50
Oxyfix® C-90 6 PE	1x230	0,08	-	-	50
Oxyfix® C-90 7 PE	1x230	0,07 - 0,075	-	-	50
Oxyfix® C-90 9 PE	1x230	0,07 - 0,075	-	-	50
Oxyfix® C-9012 PE	1x230	0,09 - 0,10	-	-	50
Oxyfix® C-9014 PE	1x230	0,11 - 0,12	-	-	50
Oxyfix® C-90 17 PE	1x230	0,11 - 0,12	-	-	50
Oxyfix® C-90 20 PE	1x230	0,17 - 0,19	-	-	50
Oxyfix® C-90 27 PE	1x230	0,29	-	-	50
Oxyfix® C-90 38 PE	1x230 ou 3x230 ou 3x400	1,5 0,81 0,81	1 x 230	0,85	50
Oxyfix® C-90 58 PE	1x230 ou 3x230 ou 3x400	1,5 1,1 1,1	1 x 230	0,85	50
Oxyfix® C-90 75 PE	1x230 ou 3x230 ou 3x400	1,5 1,1 1,1	1 x 230	0,85	50
Oxyfix® C-90 99 PE	3x230 ou 3x400	1,5	1 x 230	0,85	50

1.13.1. Connecting diaphragm blower

The blowers for Oxyfix® C-90 models 1-4 to 21-27 PE are directly connected to the mains by plugging in an electrical outlet. There are no settings to be made.



Fig-31 : Electrical connection inside a building



Fig-32 : Electrical connection inside a utility chamber

 It is strictly forbidden to cut the plug of the blower subject to voiding the warranty.

1.13.2. Connecting side chanel blower and its temperature sensor

The blowers for Oxyfix® C-90 models 28-38 to 76-99 PE and their temperature sensor are directly connected to the mains through a control panel.

To connect to the panel, please use the cables indicated in the wiring schemes provided.

The electrical connection should be done by qualified personnel in compliance with local regulations. Connect earth lines, in order to prevent electrical leakage accident. See figures below for connection :

➤ Assembly of three phase motor

The data on the nameplate of the blower show what type of assembly is required depending on the voltage requirement :

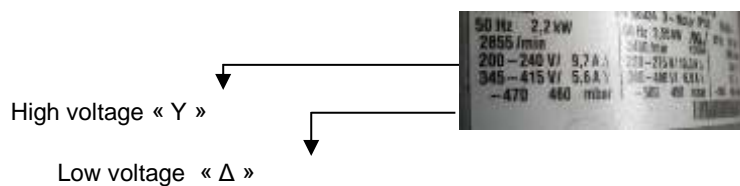

High voltage "Y" - 3x380V

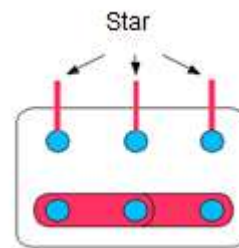

Low Voltage "Y" - 3x220V (Δ)

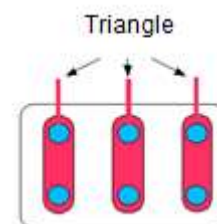

➤ Assembly of single phase motor

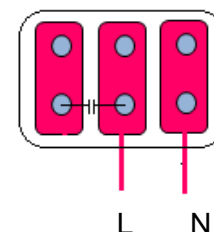

Once the electrical connections of the blower have been made, connect the two wires of the temperature sensor to the control panel by using the type of cable indicated in the wiring schemes.

In order to guarantee the sealing of the access to the electric cables, two cable glands have been provided with the air blower. The smaller one will serve as access for the temperature sensor cable, while the bigger one will serve for the access of the blower cable.



Fig 34 : The two wires of the temperature sensor



Fig 35 : Example of assembly of three phase motor



Fig 36 : Junction box

1.13.3. **Connecting electrical to panel (only applies to Oxyfix® C-90 28-38 to 76-99 PE)**

After having connected the cables to your air blower and temperature sensor, they need to be connected to your control panel. To do so, please refer to the wiring schemes provided with the panel.

⚠ After the installation, turn the blower on briefly and verify that the direction of rotation of the impeller is according the arrow and, therefore, air is sucked and blown by the respective inlet and outlet and not vice versa. If the rotation must be changed: switch any two of the drive motor wires (three-phase motor).

1.14. **Instructions for control panel using (only applies to Oxyfix® C-90 28-38 to 76-99PE)**

The electrical panel is installed in a properly ventilated, temperate, clean, dry, sheltered area and protected from splashing water. Wherever possible, please try to place the panel in a frequently visited area (garage, cellar, etc.).

⚠ It is forbidden to install the control panel in a buried utility chamber.

The electrical panel is fitted with one thermal magnetic circuit breaker, fuses, with two indicator lights (led), and a PLC complete with a LCD screen. The **green** indicator light means that the unit is working properly. The **red** indicator light indicates that there is an electrical fault.

It shall also be necessary to check daily that the unit is operating and that the control panel is energised.

1.14.1. Motors control :

⚠ Never leave the **automatic** mode of the station outside site tests or prescribed by a qualified technician in water treatment. The change of these data may lead to a malfunction of the station and cause degraded performance.

The blower and sludge pump are controlled by their own switch "I-AUTO-0".

- Position "AUTO" : automatic operation of the station motors (blower and sludge pump)
- Position "0" : station stop
- Position "I" : manual operation of the station motors (blower and sludge pump)



Fig 37 : Contactor with switch « I-AUTO-0 »

1.14.2. Load rate switch (option)

A switch allows to select the load rate of the station and modify the operating parameters of the station.

- 0 % : Station in wintering
- 50 % : Occupancy rate between 5 and 50 %
- 100 % : Occupancy rate between 51 and 100 %



Fig 38 : Load rate switch





1.14.3. Instructions for using the Siemens LOGO PLC

⚠ The modification of these parameters can lead to malfunction of the station and cause degraded performance. Only qualified technician in wastewater treatment is allowed to modify these parameters.



Fig 38 : Siemens LOGO

Navigating inside menus :

Navigation through the menus is performed using the arrow keys  . Starting from the homepage, the key  allows to navigate to the parameter screens and counters, and the key  to the active faults.

Homepage :

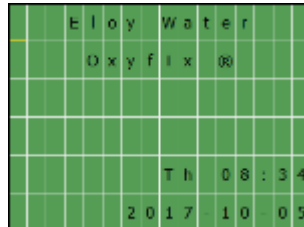

Fig-39 : Homepage

Blower parameters :

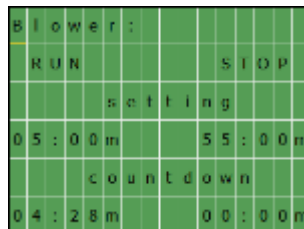

Fig-40 : "Blower" screen

This screen displays the operation time parameters of the blower in the automatic mode.

Sludge pump parameters :

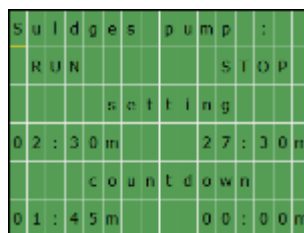

Fig-41 : "Sludge pump" screen

This screen displays the operation time parameters of the sludge pump in the automatic mode.

Operation counters :

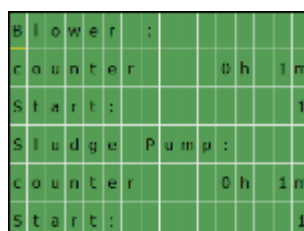



Fig-42 : "Blower and sludge pump counters" screen

This screen displays operating time counters as well as the number of starts for the blower and sludge pump.

Language modification :

The screen for language modification stands right after the one with the counters.

- Press simultaneously the keys  and  during 3 seconds (English / French)

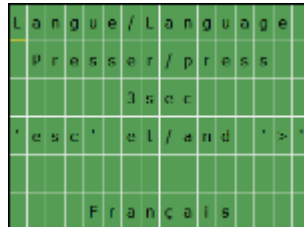



Fig-43 : "Language" screen

1.14.4. List of faults

 Only qualified BA4 or BA5 qualified persons are authorized to work on the electrical installation.

- **Blower circuit breaker fault**

The blower is protected against overload and short circuit by a magnetic circuit breaker.

Action/Solution:

- Check the state of motor/cable.
- Reset the magnetic circuit breaker (refer to point « **Erreur ! Source du renvoi introuvable. Erreur ! Source du renvoi introuvable.** »).

- **Sluges pump circuit breaker fault**

The sludges pump is protected against overload and short circuit by a magnetic circuit breaker.

Action/Solution:

- Check the state of motor/cable.
- Reset the magnetic circuit breaker (refer to point « **Erreur ! Source du renvoi introuvable. Erreur ! Source du renvoi introuvable.** »).

- **Blower thermoprobe fault**

The blower is protected against overheating.

Action/Solution:

Check the state of motor.

1.14.5. *Magnetic circuit breaker rarming procedure :*

 Only qualified BA4 or BA5 qualified persons are authorized to work on the electrical installation.



Fig 42 : **Magnetic circuit breaker**

- Red button OFF, black button ON => The magnetic circuit breaker is operational.
- Red button ON, black button OFF => The magnetic circuit breaker has been triggered.

To rearm the magnetic circuit breaker, press the black button.

If it triggers again in 10 minutes, check the current absorbed by the motor or call our technician.

Comment:

In case of persistent faults, please contact our technical service Eloy water : +32 4 382 44 22
Apart during on-site testing, do not leave the station out of another mode than automatic

2. Commissioning

The commissioning stages are as follow:

1. The foundations and the backfill are completed as recommended in the Installer's Manual. The Oxyfix® C-90 has been filled with clean water starting with the primary tank and overflowing to the other tanks until all three tanks or compartments are full of water and until the water flows out of the outlet pipe..

Warning, never attempt to fill a tank with water, even half-full, until it has been completely bacfilled all around and up to the top of the tank.

2. Once the tanks are full of water, check that the blower is indeed connected to the Oxyfix® C-90 unit with the flexible hose provided.

For the Oxyfix® C-90 7 to 99 PE, check that the recycling hose has been properly connected to the device provided in the clarifier and in the primary tank.

3. Plug the blower and the recycling pump if applicable on mains power through a control panel. within seconds of plugging the blower, fine bubbles should appear at the surface of the water in the biological reactor and the airlift of the recycling pump will recycle the water from the clarifier back to the primary tank.

4. Your unit is now functional!

It will take, from the moment where the unit receives waste waters on a daily basis, 4 weeks to establish the biomass (to bring it up to optimum performance).

3. Inspecting the Oxyfix® C-90

Now you only need to check (visually) that your unit works properly:

a. Checking the blower and the recirculation pump where applicable:

The blowers supplied with the Oxyfix® C-90 4 to 27 PE models are fitted with a red indicator light (LED), which will light-on to alert the user in the event of a blower failure. In event of a defect, **please contact +32 43 82 44 22 or your distributor.**

The blower and the recirculation pump provided with the Oxyfix C-90 38 to 99 PE are delivered complete with a control panel. The control panel class II IP65 enclosure features circuit breakers, motor controllers and two indicator lights. The green **light** indicates that the unit is working properly. Any electrical fault shuts the affected component and lights-up **red**. In the event of a failure, you must open the enclosure and check if the circuit breaker has tripped or not. If the breaker is tripped, it is possible to reset it again. If you are not able to reset the circuit breaker, **please contact your distributor.**

b. Checking the air blower: it is useful, once a month, to visually check that the air is blowing properly through the biological reactor by raising the manhole cover. Fine bubbles dispersing in a uniform pattern to the surface of the reactor indicates that your Oxyfix® unit is operating properly. Please contact your distributor if you cannot see the fine bubbles dispersing in a uniform pattern to the surface of the reactor. Be careful, there is a temporisation on the blowers.

- c. **Checking the recirculation system:** it is necessary from time to time to check if the system that recirculates the settled sludge from the clarifier back to the primary decanter works properly. Please contact your distributor if the recirculation system does not work properly. Be careful, there is a temporisation on the chanel blowers.
- d. **Checking the treated water discharge:** Your Oxyfix® features a sampling device inside the clarifier: the water in the sampling device should be clear at all times. If it appears brownish or if it is smelly and that all of the parameters listed above have been thoroughly checked, **please contact your distributor.**

Checking the level of sludge in the primary decanter and emptying the excess sludge.
The frequency at which the sludge needs to be removed depends largely on the rate at which the primary decanter is filled with waste water. The level is assessed by the serviceman during his (bis)-annual service inspection.

4. FAQs

General Information on your Oxyfix® C-90

➤ **What is submerged aerobic fixed-film technology?**

Your Oxyfix® uses a cost-effective method of waste water treatment known as submerged aerobic fixed-film technology, i.e. that the sewage is broken down by aerobic micro-organisms that are fixed to a submerged media, the Oxybee®. Bacteria clings onto these Oxybees® to form a thin layer and to breakdown the organic matter. The air blown throughout the media, supplied by an air blower and an uncloggable fine air diffuser will stimulate the development of aerobic bacteria.

➤ **What's the Oxybee®?**

Oxybee® is a bacterial media specifically designed by the engineers at Eloy Water. Inspired by nature, our team has developed a lightweight and age resistant honeycomb shaped material using recycled plastic (PP, PE). Its high surface area (200m²/m³) allows for maximum biofilm development without any risk of clogging (90% of empty space). The Oxybee® are unalterable, and never need to be replaced.

➤ **Is the Oxyfix® C-90 unit certified?**

Eloy Water has been awarded a number of certifications including France, Belgium, Australian and New Zealand Certification.

➤ **What will be the visual impact of my Oxyfix® C-90 on my property?**

Given that this is a completely buried system, the visual impact will be insignificant

Implementation and installation

➤ **What are the installation requirements for venting my unit?**

The compartment storing the sludge must be fitted with a 100mm or with a larger diameter vent pipe, separated from the treated and rain water pipes and run sufficiently high above the roof line to dissipate all noxious smells.

➤ **What is the maximum allowed thickness of backfill?**

The C-90 concrete tank are designed to support up to a maximum of 80 cm of backfill (20cm for Oxyfix C-90 15-17 and 18-20PE) in addition to the pedestrian loading. In the event where these conditions are not complied with (thicker soil cover), a concrete topping slab must be cast in place.

➤ **What is the maximum distance allowed between the blower and the treatment unit?**

20 metres. If the distance is less than 20 metres, please cut the pipe in order to decrease the load losses.

➤ **Where should I put the blower?**

The blower must be installed in a properly ventilated, temperate, clean, dry, sheltered area and protected from splashing water.

Wherever possible, please try to place the blower in a frequently visited area (garage, cellar, etc.) remembering that the blower is fitted with a red indicator light that lights up in the event of a malfunction.

➤ **Can I install my unit above ground?**

No. The tank was not designed to be installed above ground.

➤ **Can I install my unit half-buried?**

Yes, provided the tank is enclosed within an embankment and that there is no risk of freezing.

➤ **Can rainwater drains be connected to the water treatment unit?**

No. Storm water shall not under any circumstance flow through the treatment unit.

➤ **What measures should be taken in order to allow the passage of vPEicles above the buried tank?**

Oxyfix® C-90 units supplied with 7.5m³ tanks, used in a trafficable area will require a topping slab on top of the tank. No moving or static load shall be allowed within a distance of 2.85m from the unit.

Oxyfix® units delivered with 4.5, 6, 10, 15 and 20m³ tanks and used in a trafficable area used by vPEicles heavier than 3.5 tonnes, will require a topping slab on top of the tank.

➤ **What type of cover risers should I use for the backfill thickness used?**

For backfill thicknesses of 0 to 60cm, use cover risers of 600mm in diameter in order to ensure easy access to the different components of your water treatment unit.

If the backfill thickness is 60 to 80cm, use square cover risers of 80x80cm).

➤ **What should I do if there is water at the bottom of the digging at the time of lowering the unit in the ground?**

Please refer to the installation procedures (Installation Manual, section 1.10).

➤ **What is the diameter of the protective sheaths?**

It is recommended to use protective sheaths with a minimum diameter of :

- 63mm for diaphragms blowers pipe;
- 90mm for side channel blowers pipe;
- 100mm for sludge recirculation pipe provided with Oxyfix® C-90 7 to 27PE;
- 90mm for sludge recirculation pipe provided with Oxyfix® C-90 38 to 99 PE.

Use and maintenance

➤ **Is maintenance mandatory?**

Local regulations require the users to have their water treatment units serviced regularly, however the service agreement is optional.

Just like your vPEicle, your unit should be serviced regularly to efficiently operate. Fortunately, your Oxyfix® C-90 unit only requires a minimum of service or repair actions. However, some service actions may require the help of a professional. This is the reason why we offer a service agreement that guarantees the long term performance and that extends our warranty.

➤ **What will happen if I do not service my unit?**

You risk having more and more recurrent technical problems arising. This may diminish the treatment efficiency of your unit and also increase the emptying frequencies.

➤ **When should I empty the unit?**

If you have agreed to a service agreement, you will have to empty the primary decanter (the first compartment of the unit) whenever the field service person reports it on the inspection report.

Otherwise, we recommend that you should empty the tank when the primary decanter of your Oxyfix® C-90 is 70% full.

➤ **Must I refill the unit with water after emptying the sludge from the unit?**

Yes, but be careful! You must follow the emptying and filling procedures in order not to damage the unit.

➤ **Can I install a timer on my membranes blower?**

No! Your unit has been designed to use the blower continuously. A timeout could perturb the growth of the micro-organisms.

However, and in a some very special cases, (dissolved oxygen measurements during servicing, country home, etc. ..), a timer may be installed on the blower but the timeout must never exceed 30 minutes.

To find out if your unit qualifies for operating under these conditions, please contact Eloy Water's customer service department at: support@eloywater.com.

➤ **Can I disconnect my membranes blower (Oxyfix C-90 1 to 27 PE) when going on holidays?**

No.

➤ **The air outlet of the blower is leaking, is this normal?**

No, the air supply pipe was probably poorly fitted. Please check the hose clamps and the small rubber end piece if required.

➤ **The motor of the blower is hot, is this normal?**

Yes, the motor will heat up. If it overheats abnormally, the blower will go into safe mode and will cut out long enough to cool.

➤ **The red light of my diaphragm blower (Oxyfix C-90 1 to 27 PE) is on, what does that mean?**

The device went into safe mode, ruptured diaphragms. This can be repaired by our technical service people.

➤ **The diaphragm blower has stopped, what should I do?**

Check if the red light on the blower is turned on. If it is, this means that the diaphragms have ruptured; if it is not, it is preferable for you to call our customer service department at (support@eloywater.com).

➤ **How much power does the blower consume?**

The power rating is indicated on the nameplate of the blower. You will also find this information in section 1.13 of the installation manual.

➤ **How often does the blower need to be replaced?**

Theoretically, a blower must be replaced after 15 years of operation.

However, the air filter must be checked during each repair or service action and replaced every two years. A clogged filter must be cleaned.

The diaphragms on the diaphragm blowers (Oxyfix C-90 1 to 27 PE), need to be replaced every 3 years.

➤ **How often do the air diffusers need to be replaced?**

Theoretically every 8 years, but less frequently in practice.

➤ **Can the treated waste water be recycled?**

It is forbidden to recycle the treated water unless it is further appropriately treated (UV, reverse osmosis, chlorination, ..). Given that these waters still contain many pathogens (viruses, bacteria, etc.).

➤ **What should I do if there is a smell around the unit?**

Check that the venting system is not blocked, if it protrudes well above the roof line and whether it is fitted with a static or a wind powered extractor.

➤ **What should I do if there is a smell inside the house?**

Check that all the siphons in the house ensuring that they remain well under water.

➤ **There is crust floating on the surface of the clarifier. What should I do?**

This floating crust should normally be removed during the service or repair action. However, should this crust thicken, you may skim it back towards the primary decanter.

➤ **The sanitary appliances are not flushing out properly, what should I do?**

There are several reasons for this:

1. There is probably a blockage upstream of the tank and/or of the T inlet to the tank.
If this is the case, you must clear the blockage.
2. The tank is full of solids. It must be emptied.

If you have any further questions, please contact Eloy Water's customer service department at maintenance @ eloywater.com.

➤ **Can I ask any Tank cleaning service to empty my unit?**

No, the tank has to be emptied by an accredited cleaning service.