

X-PERCO C-90 15-20 EH (3)

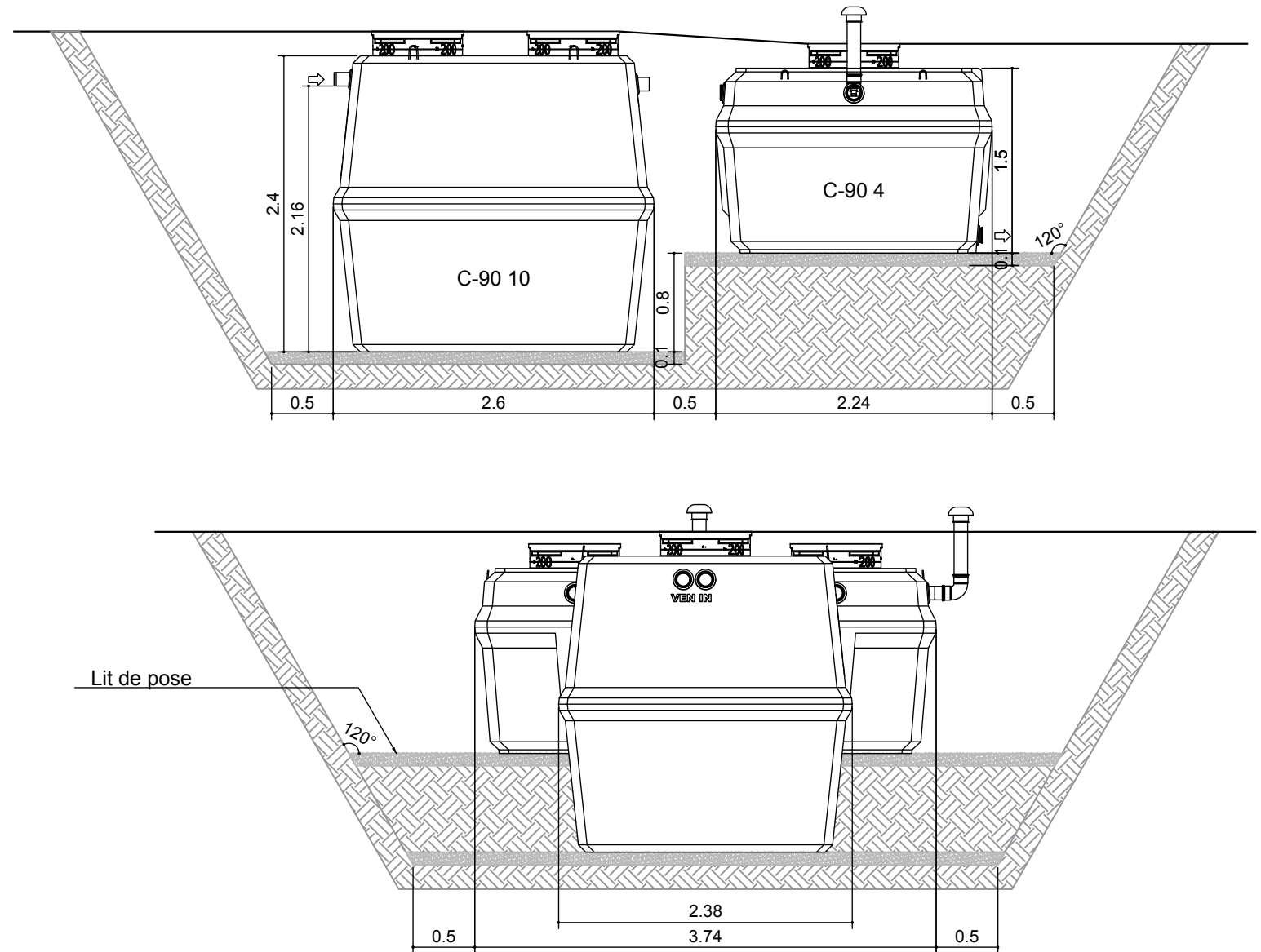
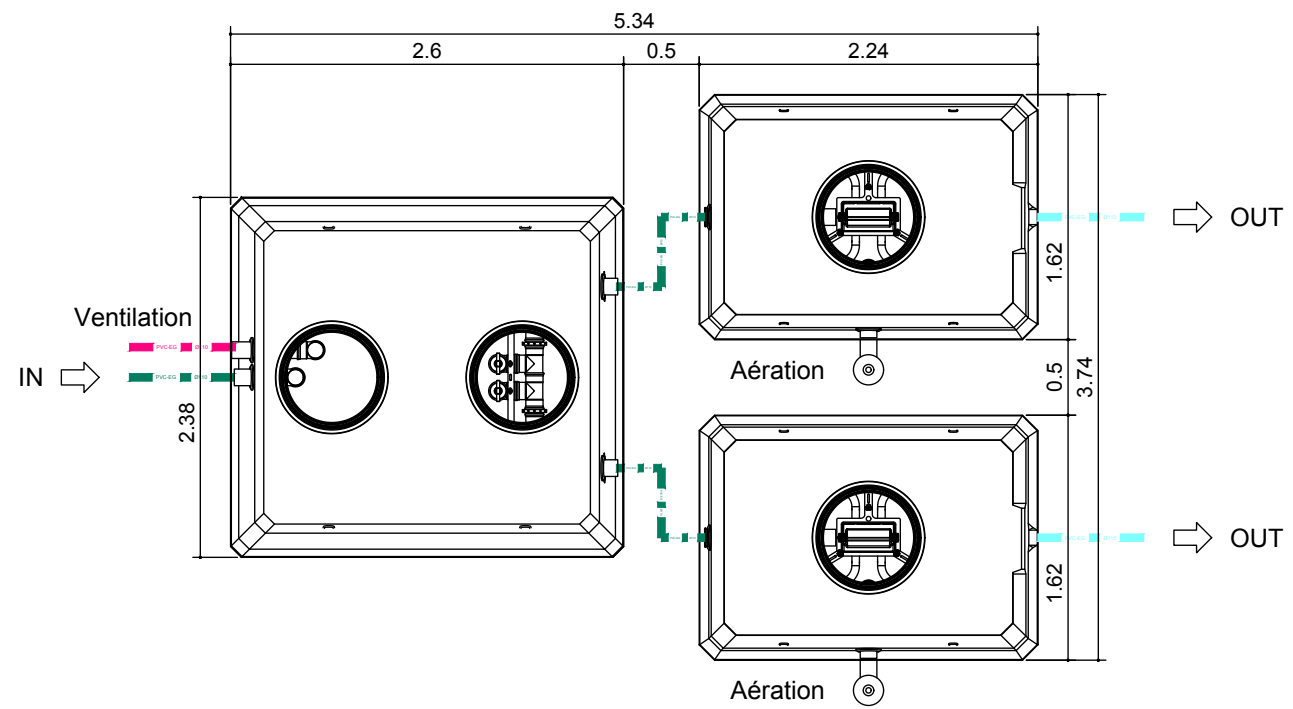

LEGENDE TUYAUTERIE
Nature du produit véhiculé (couleur)

■ Eau usée	■ Air surpressé
■ Eau traitée	■ Ventilation
■ Boue	■ Gaine électrique

REMARQUES:

- Conditions de pose:**
Merci de lire attentivement le guide de mise en œuvre avant toute installation !!
- Tolérances sur les dimensions:**
2%
- Option(s):**
Tuyauterie, rehausses, trappillons et accessoires en option.

A		2/12/2019	ADMIN		
Rev	DESCRIPTIONS	DATE	DESIGNER	VERIFIED BY	VALIDED BY



Zoning de Damré, rue des Spinettes 13
4140 Sprimont (BELGIUM)
Tel: +32(0)4/382.34.44
<http://www.eloywater.com> - info@eloywater.com

X-PERCO C90 20 EH (3) / 3 m³/jour

Plan d'implantation

GAMME STANDARD
X-PERCO C90 FR

1/50 A3

EW-1905-20-I03-FR.dwg